



## Square-Gear



## Use and maintenance manual

Manuale uso e manutenzione



Catalogue code: MA-VFM-Q-HM015

# HYDRO-MECHANICAL

**GENERALITY**

The gearboxes do not fall within the scope of Machinery Directive 2006/42 / EC, as they are identified as components of the machine.

Article. 35 of the guide to the Machinery Directive states:

"The Machinery Directive does not apply directly to the components of the machines, such as, for example, the speed reducers, which does not have a specific application as such, but are intended to be incorporated in machines, although the design and construction of such components must be such as to make the machine completed in compliance with the relevant requirements and basic safety and health protection. "

Smooth operation and the right to request under guarantee require compliance with the information contained in this manual, which must be read before starting up the group.

The gearboxes, which are not an integral part of a machine properly defined, are not nearly machines, but they are only components, therefore do not fall in the purposes of Machinery Directive 2006/42 / EC.e 2006/42 / EC.

**GENERALITA'**

I riduttori di velocità non ricadono nel campo d'applicazione della Direttiva Macchine 2006/42/CE, in quanto sono identificati come componenti di macchina.

L'art. 35 della guida alla Direttiva Macchine stabilisce: "La Direttiva Macchine non si applica direttamente ai componenti delle macchine, quali, per esempio i riduttori di velocità, che non hanno un'applicazione specifica in quanto tali, ma sono destinati ad essere incorporati nelle macchine, sebbene la progettazione e la costruzione di detti componenti devono essere tali da rendere la macchina completata conforme ai requisiti pertinenti e fondamentali in materia di sicurezza e di tutela della salute."

Il funzionamento regolare ed il diritto alla richiesta di prestazioni in garanzia richiedono il rispetto delle informazioni contenute nel presente manuale che deve essere letto prima della messa in funzione del gruppo.

I Riduttori, che non sono parte integrante di una macchina propriamente definita, non sono quasi macchine, ma sono solo componenti, pertanto non ricadono negli scopi della Direttiva Macchine 2006/42/CE.

**SAFETY**

- Written authorization is required to operate or use reducers in man lift or people moving devices.
- Check to make sure that certain applications do not exceed the allowable load capacities published in the current catalog.
- Buyer shall be solely responsible for determining the adequacy of the product for any and all uses to which Buyer shall apply the product. The application by Buyer shall not be subject to any implied warranty of fitness for a particular purpose.
- For safety, Buyer or User should provide protective guards over all shaft extensions and any moving apparatus mounted thereon. The User is responsible for checking all applicable safety codes in his area and providing suitable guards. Failure to do so may result in bodily injury and/or damage to equipment.
- Gearboxes operating in high position should have a protective shield for any possible parts falling down for casual accidents where people are moving under them.
- Hot oil and reducers can cause severe burns. Use extreme care when removing lubrication plugs and vents.
- Make certain that the power supply is disconnected before attempting to service or remove any components. Lock out the power supply and tag it to prevent unexpected application power.
- Reducers are not to be considered fail safe or self-locking devices. If these features are required, a properly sized, independent holding device should be utilized. Reducers should not be used as a brake.
- Any brakes that are used in conjunction with a reducer must be sized or positioned in such a way so as to not subject the reducer to loads beyond the catalog rating.
- Lifting supports including eyebolts are to be used for vertically lifting the gearbox only and not other associated attachments or motors.
- Use of an oil with an EP additive on units with backstops may prevent proper operation of the backstop. Injury to personnel, damage to the reducer or other equipment may result.
- Overhung loads subject shaft bearings and shafts to stress which may cause premature bearing failure and or shaft breakage from bending fatigue, if not sized properly.

**SICUREZZA**

- E' richiesta autorizzazione scritta per azionare riduttori in ascensori o dispositivi per il movimento delle persone.
- Controllare che alcune applicazioni non eccedano la massima capacità di carico ammessa pubblicata in questo catalogo.
- L'acquirente è l'unico responsabile per la determinazione dell'adeguatezza del prodotto per qualcuna o tutte le utilizzazioni che l'acquirente stesso farà del riduttore. L'applicazione dell'acquirente non potrà essere soggetta ad alcuna implicita garanzia di montaggio per uno scopo particolare.
- Per ragioni di sicurezza l'acquirente dovrà provvedere a porre protezioni adeguate su tutta la lunghezza dell'albero a tutti gli organi in movimento. L'utilizzatore è responsabile del controllo di tutti i codici di sicurezza e la predisposizione di protezioni adeguate. In assenza di tali precauzioni si possono verificare incidenti alle persone e danni agli apparati.
- Su riduttori installati in posizioni elevate utilizzare protezioni adeguate per qualsiasi distacco accidentale di parti nel caso di passaggio di persone al di sotto.
- Olio e riduttori bollenti possono causare gravi ustioni. Usare estrema cautela nella rimozione dei tappi e delle ventole.
- Assicurarsi che la corrente di alimentazione sia scollegata prima di riparare o rimuovere alcun componente. Chiudere l'alimentazione e contrassegnare tale operazione per evitare accensioni accidentali.
- I riduttori non devono essere considerati esenti da guasti o a bloccaggio automatico. Se sono indispensabili queste caratteristiche, deve essere utilizzato un dispositivo indipendente della dimensione adatta. I riduttori non devono essere utilizzati come freni.
- Qualsiasi freno sia utilizzato insieme al riduttore deve essere della giusta grandezza e posizionato in modo da non causare carichi eccessivi non previsti dai dati forniti nel catalogo.
- I dispositivi di sollevamento come le golfare devono essere usati solo per sollevare verticalmente il riduttore e non altri di spositivi associati o motori.
- L'utilizzo di un olio con un additivo EP su gruppi provvisti di dispositivo di arresto possono inficiare l'uso corretto del freno e provocare danni alle persone, alle cose ed al riduttore stesso nonché ad altri apparecchi.
- I Carichi sospesi assoggettano i cuscinetti della vite e la vite stessa a sollecitazioni che possono causare, se non adeguatamente dimensionati, l'usura prematura dei cuscinetti e/o la rottura della vite a causa della resistenza alla flessione.

## SAFETY

Gearboxes in this manual are intended for use in industrial applications and meet the standards and regulations that can be adopted.

The performance and specifications are traceable on the nameplate and related documentation.

### Transport

Carefully check the status upon receipt and any damage immediately to the carrier.

## ASSEMBLY OF PRODUCTS

The following assembly drawings are meant to assist in the search of the main components of the various types of gearbox.

The various designs and dimensions, assembling versions, number of stages, actually generate multiple solutions and therefore we invite you to apply for specific documentation.

## SICUREZZA

I riduttori presenti in questo manuale sono rivolti ad uso in applicazioni industriali e corrispondono agli standard e alle regolamentazioni adottabili.

Le prestazioni e i dati tecnici sono rintracciabili sulla targhetta e sulla relativa documentazione .

### Trasporto

Verificare con attenzione lo stato al ricevimento e contestare immediatamente eventuali danni al trasportatore.

## ASSEMBLAGGIO DEI PRODOTTI

I seguenti disegni di assieme hanno come fine di aiutare nella ricerca dei componenti principali dei vari tipi di riduttore

Le varie forme costruttive e dimensionali, delle versioni di montaggio, del numero di coppie di riduzione, generano in realtà molteplici soluzioni e pertanto si invita a richiedere la documentazione specifica.

# SELECTION CHECK LIST

Please Check

EN

I

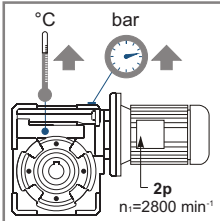

High speed motors, Higher than 1800 rpm, can produce high operating temperatures within the reducer and should only be used for intermittent duty applications. Decrease the reducer's lubricant levels and install a breather plug.

Nell'utilizzo di motori a 2 Poli durante il funzionamento si possono registrare elevate temperature di funzionamento e pressioni interne. Si consiglia l'uso di tali motori solo per servizi intermittenti. Ridurre il livello di lubrificante ed installare un tappo di sfiato.

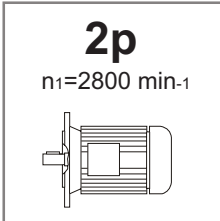

2 poles motors can be used only for very intermittent applications. Specify it in the order to select the most suitable ratios. Please specify in the order if you required a particular level of noise.

Specificare in fase d'ordine se in fase di utilizzo si applica un motore 2 poli.

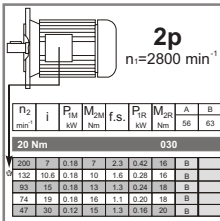

With 2 poles motor if a particular " low noise" is required ask us the most suitable ratio.

Qualora (con il motore a 2 poli) sia richiesta una particolare silenziosità richiedete i rapporti più idonei.

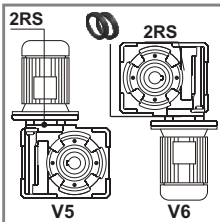

Please specify when ordering if reducer are used in Vertical V5 or V6 mounting position. We normally mount a 2RS self lubricated bearings ( see picture ) for V6 mounting we recommend double oil seals in the input side V6 positions is not recommended for 2 poles motors

Specificare in fase d'ordine se i riduttori richiesti vengono utilizzati per posizioni di montaggio verticali V5÷V6. Per queste posizioni va previsto un cuscinetto schermato 2RS come in figura. Per montaggio V6 suggeriamo l'uso di 2 anelli di tenuta in entrata. V6 (Posizione sconsigliata con motori 2 Poli).

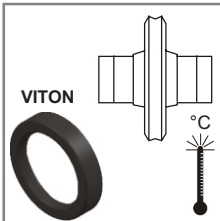

In case of high temperatures we suggest to use FPM (fkm) Oil seals in the output shaft.

In caso di temperature elevate consigliamo di montare anelli di tenuta in FPM (fkm) sul mozzo.

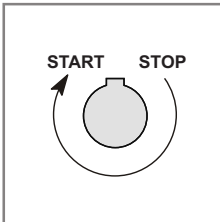

For applications having frequent starts and stops it is recommended to use two oil seals or double lip oil seals to avoid premature wear of the oil seals.

Per applicazioni con un numero elevato di avviamenti / arresti è consigliabile montare due anelli di tenuta (dove è possibile) sull'albero di uscita.

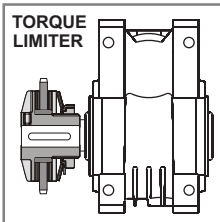

If the application is with high shock loads and sudden stops it's suggested to use mechanical or electronic torque limiting devices.

Se nell'applicazione si prevedono sovraccarichi prolungati, urti o bloccaggi improvvisi, installare sistemi meccanici o elettronici di limitazione della coppia.

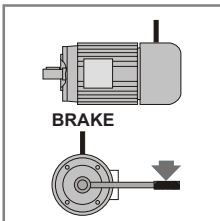

Reducers are not to be considered fail safe or self-locking devices. If these features are required, a properly sized, independent holding device should be used. Reducers should not be used as a brake. Any brakes that are used in conjunction with a reducer must be sized or positioned in such a way so as to not subject the reducer to loads beyond the catalog rating.

Segnalare se l'utilizzo è con motore autofrenante con elevati numeri di manovra. Nelle installazioni accertarsi che la coppia generata dal l'inerzia del carico in fase di frenatura non superi i limiti del riduttore; verificare (con chiave dinamometrica) che la coppia di taratura del freno corrisponda ai dati convalidati dal progetto.

For a proper selection of the required gearbox it is important to follow the following table:

Per una corretta selezione del riduttore o motoriduttore è importante rispettare le seguenti indicazioni:

**Service factor**  
**Fattore di servizio**

**1** Find out the application service factor through the following table.

Determinare tramite la seguente tabella il fattore di servizio **fs** relativo all'applicazione.

Type of load and starts per hour Tipo di carico e avviamenti per ora		fs			
		Oper. hours per day Ore di funz. giorn.			
		<2 h	2 - 8 h	8 - 16 h	
Continuous or intermittent appl. with start/hour Applicazione cont. o interm. con n.ro operazioni/ora	≤ 10	Uniform / Uniforme	0.9	1	1.25
		Moderate / Moderato	1	1.25	1.5
		Heavy / Forte	1.25	1.5	1.75
Intermittent application with start/hour Applicazione intermittente con n.ro operazioni/ora	> 10	Uniform / Uniforme	1.25	1.5	1.75
		Moderate / Moderato	1.5	1.75	2
		Heavy / Forte	1.75	2	2.25

N.B. For applications with flameproof motors or instantaneous reversal, multiply the service coefficient by 1.15.

N.B. Per azionamenti con motore a scoppio o per funzionamento alternato istantaneo, moltiplicare il valore del coefficiente di servizio per 1.15.

**Gearbox selection**  
**Scelta di un riduttore**

**2** A gear box version R (or B) is to be found from the selection tables, considering the required power  $P_{1r}$  (or torque  $M_{2r}$  required) and output speed  $n_2$  referred to 1400 min<sup>-1</sup> (or to gearbox ratio).  
Once the gearbox has been chosen,  $P_{1R}$  power and  $n_1$  speed (given in the table), it should comply with the following conditions:

Un riduttore nella configurazione R (o B) dovrà essere ricercato nelle tabelle di selezione riduttori in base alla potenza richiesta  $P_{1r}$  (o alla coppia richiesta  $M_{2r}$ ) e ai giri uscita  $n_2$  riferiti a 1400 min<sup>-1</sup> (o al rapporto di trasmissione i).  
Il riduttore selezionato in base alla potenza  $P_{1R}$  (indicata in tabella) e a  $n_1$  dovrà soddisfare le seguenti condizioni:

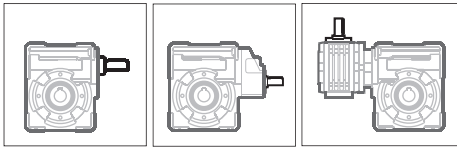

2 Poles  
2 Poli



$n_1 = 1400 \text{ min}^{-1}$

$P_{1R} \geq P_{1r} \times fs$

$n_1 = 2800 \text{ min}^{-1}$

$P_{1R} \times 1.6 \geq P_{1r} \times fs$

Where 2 pole motors are required, specify when placing order to foresee lubricant and synthetic oil.

Per l'abbinamento a motori a 2800 min<sup>-1</sup>, specificare sempre tale caratteristica in fase di ordine per prevedere lubrificante e olio sintetico.

6 Poles  
6 Poli



$n_1 = 900 \text{ min}^{-1}$

$P_{1R} / 1.5 \geq P_{1r} \times fs$

Following symbols will be found in the selection tables of the gearboxes:

Alle tabelle di selezione dei riduttori è associata la seguente simbologia:

$n_2$ [min <sup>-1</sup> ]	i	$P_{1M}$ [kW]	$M_{2M}$ [Nm]	f.s.	$P_{1R}$ [kW]	$M_{2R}$ [Nm]
-------------------------------	---	------------------	------------------	------	------------------	------------------

- $n_2$  [min<sup>-1</sup>] output speed ( $n_1 = 1400 \text{ min}^{-1}$ )
- i — reduction ratio
- $P_{1M}$  [kW] motor input power ( $n_1 = 1400 \text{ min}^{-1}$ )
- $M_{2M}$  [Nm] output torque ( $n_1 = 1400 \text{ min}^{-1}$ )
- $P_{1R}$  [kW] Transmitted power at input gearbox
- $M_{2R}$  [Nm] Transmitted output torque
- RD — Dynamic efficiency
- Mn — Tooth normal module

- $n_2$  [min<sup>-1</sup>] giri in uscita ( $n_1 = 1400 \text{ min}^{-1}$ )
- i — rapporto di riduzione
- $P_{1M}$  [kW] potenza nominale motore ( $n_1 = 1400 \text{ min}^{-1}$ )
- $M_{2M}$  [Nm] coppia in uscita ( $n_1 = 1400 \text{ min}^{-1}$ )
- $P_{1R}$  [kW] potenza trasmessa in entrata
- $M_{2R}$  [Nm] coppia trasmessa in uscita
- RD — rendimento dinamico
- Mn — modulo normale del dente

**20 Nm**

200	7	0.18	7	2.3	0.42	16
132	10.6	0.18	10	1.6	0.28	16
93	15	0.18	13	1.3	0.24	18
74	19	0.18	16	1.1	0.20	18
47	30	0.12	15	1.3	0.16	20





An easier selection of the motorized gearbox (closer as possible to sf 1) can be done through our gear selection table (Point 2). In fact only 4 pole motors (1400 min<sup>-1</sup>) are listed here .

Una selezione semplificata del motoriduttore in base ad un unico fattore di servizio (il più prossimo a 1) può essere effettuata tramite le tabelle di selezione riduttori (punto 2). In questo caso sono riportati solo motoriduttori con motori a 4 poli (1400 min<sup>-1</sup>).

**Gearbox coupled to a speed variator**  
**Riduttore con variatore di velocità**

- 5** Where a hydraulic or mechanic variator is connect to a gearbox, it is necessary to consider if there is a low output speed, when the input speed is decreasing,  $M_2$  torques can easily exceed their nominal values. In high reduction ratios this effect should be taken even in more consideration.

Qualora al riduttore venga abbinato un variatore idraulico o meccanico, è necessario considerare che a bassi giri, al diminuire della velocità d'ingresso, le coppie  $M_2$  possono superare anche notevolmente il valore nominale. Tale effetto deve essere maggiormente tenuto in considerazione nei rapporti elevati.

**Gearbox equipped with a brake motor**  
**Riduttore con motore autofrenante**

- 6** For selection with brake motors, make sure that the torque generated by the load inertia during braking does not exceed the gearbox limits; check ( with the appropriate torque meter ) that brake torque matches the data given in the project.

Nella selezione con motori autofrenanti, potendo essere considerevole l'effetto inerziale delle masse, è opportuno scegliere riduttori con  $f_s \geq 1$ .

**Selections not listed in the catalogue**  
**Selezioni fuori catalogo**

- 7** In cases where higher powers than the ones given in this catalogue have to be used, our factory cannot guarantee the proper operation of the gearbox.

Nel caso vengano applicate potenze superiori a quelle indicate a catalogo, la nostra ditta non può garantire il corretto funzionamento del gruppo.

**Notes**  
**Note**

- 8** It is necessary to refer the following the applications to our technical service.
- Applications where gearbox failure is critical.
  - Applications with particularly high inertias
  - Lifting devices.
  - High dynamic stress on gearbox housing.
  - Particular environment conditions with temperatures lower than 5°C or higher than 40°C.
  - Highly chemical aggressive environment.
  - Salty environment.
  - Applications not considered in the catalogue.
  - Radioactive environment.
  - Pressure different to atmospheric.
  - Avoid those applications where total or partial immersion of the gearbox is required.

Occorre tenere nella giusta considerazione e valutare attentamente le segg. applicazioni consultando il ns. Servizio Tecnico.

- Utilizzo in servizi che potrebbero risultare pericolosi per l'uomo in caso di rottura del riduttore.
- Applicazioni con inerzie particolarmente elevate.
- Utilizzo come organo di sollevamento.
- Applicazioni con elevate sollecitazioni dinamiche sulla cassa del riduttore.
- Utilizzo in ambiente con temperatura inferiore a 5°C o superiore a 40°C.
- Utilizzo in ambiente con presenza di aggressivi chimici.
- Utilizzo in ambiente salmastro.
- Posizioni di piazzamento non previste a catalogo.
- Utilizzo in ambiente radioattivo.
- Utilizzo in ambiente con pressione diversa da quella atmosferica.
- Evitare applicazioni dove è prevista l'immersione, anche parziale, del riduttore.



**Thermal limit  
Limite termico**

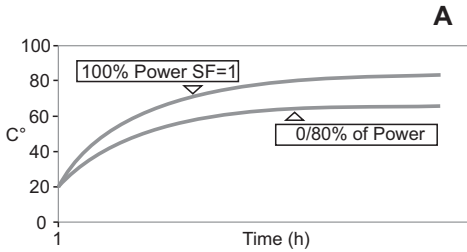

Worm gearboxes, because of their inside design, transform part of their installed power into heat which is subsequently disposed of throughout the housing and may result into values, measured onto the gear case in the area of the worm shaft, in the range of 80 - 100 °C without this affecting the operation of the gear unit adversely.

The diagram of the temperature increase depending on the operating time is illustrated in graph A. Final temperature is given by the sum of several components :

- Installed power and percentage of usage
- Ambient temperature
- Lubrication
- Cooling method
- Input speed

I riduttori a vite senza fine, dato lo schema costruttivo, trasformano parte della potenza installata in calore che viene smaltito dalla carcassa e in corrispondenza della vite senza fine può raggiungere valori misurati nell'intorno di 80 - 100 °C senza che questo pregiudichi la meccanica del riduttore.

Il diagramma dell'incremento della temperature in funzione del tempo di funzionamento è illustrato nel grafico A.

La temperatura finale raggiunta è data dalla somma di varie componenti:

- Potenza installata e percentuale di utilizzo
- Temperatura ambiente
- Tipo di lubrificazione
- Tipo di raffreddamento
- Velocità in ingresso

**Thermal limit with intermittent duty  
Limite termico per funzionamento intermittente**

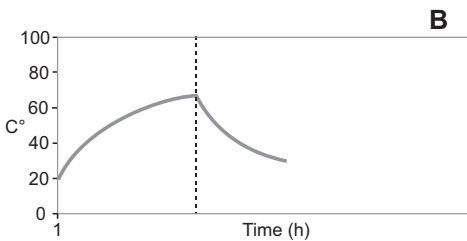

In this case the temperature increase curve is similar to the one for continuous duty. In fact the peak is reached in approximately 20/30 minutes using 100% of the power.

The gearbox can be stopped at any point of this curve then following a cooling curve whose shape depends on the ambient temperature (graph B).

In questo caso la curva di aumento temperatura è simile a quella del funzionamento continuo e normalmente viene raggiunto il valore massimo in 20/30 minuti circa e con il 100% della potenza utilizzata.

In qualsiasi punto di tale curva venga quindi a fermarsi il riduttore, si crea una curva di raffreddamento che è più o meno rapida a seconda della temperatura ambiente (grafico B).

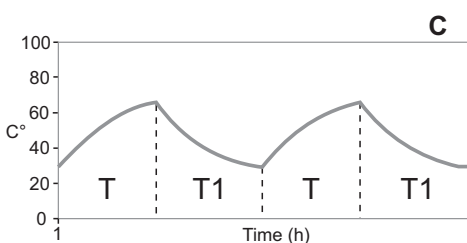

Should the gearbox have several starts and stops cycles, the final temperature depends on starts and stops times (very similar to electric motors with operation S3 and S6 see graphs C and D).

Service factor values indicated in this catalogue refer to an intermittent duty.

Se il riduttore ha poi cicli di arresti ed avviamenti, la temperatura finale dipende dal tempo di arresto e di funzionamento (con un comportamento molto simile a quello dei motori elettrici con funzionamento S3 o S6, vedi grafici C e D).

I valori del fattore di servizio  $f_s=1$  riportati in questo catalogo si riferiscono ad un tipo di funzionamento intermittente.

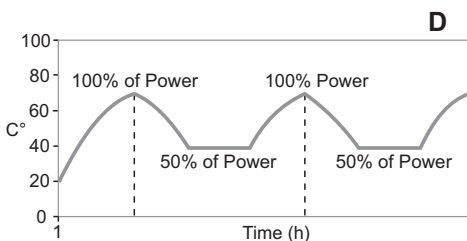

**Geared motor selections with 2800 min<sup>-1</sup> input speed are tolerated for intermittent duty applications only, because of the high temperature in crease resulting from the input rotation speed.**

**For these cases please contact technical department.**

**La selezione di motorizzazioni con velocità in entrata a 2800 min<sup>-1</sup> è ammessa per applicazioni intermittenti, dato l'elevato aumento della temperatura di funzionamento derivante dalla elevata velocità di rotazione.**

**In questo caso interpellare il nostro Servizio tecnico Commerciale.**

**Irreversibility  
Irreversibilità**

With wormgear boxes it is always important to consider the several levels of reversibility (or irreversibility) of the worm gear set, in order to guarantee a correct selection in applications where these requirements are essential for the operation of the machine. The following table shows the different tables of reversibility for worm gearboxes according to helix angle  $\beta$  and reduction ratio  $i$ .

Nei riduttori a vite senza fine è importante tenere in considerazione i vari gradi di reversibilità (o irreversibilità) della coppia vite-corona, per garantire una corretta selezione nelle applicazioni dove queste esigenze sono determinanti al fine del buon funzionamento dell'impianto. La tabella seguente riporta i vari gradi di reversibilità nei riduttori a vite senza fine definiti in base all'angolo d'elica  $\beta$  e al rapporto di riduzione  $i$ .

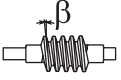
	Q30	Q45	Q50	Q63	Q75	Q85	Q11	Q13	Q15	P4Q	P5Q	P6Q	P7Q	P8Q	P1Q	43Q	53Q	63Q	64Q	74Q	84Q	15Q
	i									i						i						
>25°		7		7	7	7	7	7.5	7.5	30.1												
12° - 25°	5 7 10 15	10 14	7 10	10 15	10 15	10 14 20 22	10 16 20 23	10 15 20	10 15 20	43.0 60.2	30.1 43.0					42 48 125					140	
8° - 12°	20	21	14 18	19 24	20 25			25	25 30	90.3	60.2 77.4	29.9 37.7 87.8 111				140 200 280 420						
5° - 8°	30	28	26 30 36	30 36 40	31 40	28 38 46 52	30 38 45 53 64	30 40 50 60	40 50	120	112 155	47.1 56.6 139 166	62.9 94.3 185 277 378	59.7 72.3 81.7 213 240 328	83.2 101 176 208 245 296 334 403	560	252 360 540 720	252 360 540 1080	252 360 504 756 1008	280 400 560 840 1120	196 280 392 588 784	210 300 420 540 780 1080
3° - 5°	40	37 46 60	43 50 60 68	45 60 67 80	50 60 80	67 74 96	84 99	80 100	80 100	159 198 258	185 258 292	70.7 208 310 370	78.6 126 231 504	105 422 466 605	132 529 624	740 920 1120 1440 1480 1840 2400	860 1200 1440 2400	1440	1332 1656 2160	1480 1840 2400	1036 1288	1290 1800 2040
1° - 3°	61 80 100	70 102	80 100	94	100					301 439	344 430	434	157 630					2745	2520	2800 4080	1960 2856	2400 3000

>25°	Totally reversible	Reversibilità totale
12° - 25°	Statically reversible Quick return Dynamically reversible	Staticamente reversibile Ritorno rapido Dinamicamente reversibile
8° - 12°	Variable static non-reversing Quick return in case of vibrations Dynamically reversible	Irreversibilità statica incerta Ritorno rapido in caso di vibrazioni Dinamicamente reversibile
5° - 8°	Statically non-reversing Return in case of vibrations Bad dynamic reversing	Staticamente irreversibile Ritorno in caso di vibrazioni Cattiva reversibilità dinamica
3° - 5°	Statically non-reversing Slow movement return in case of vibrations Low dynamic reversing*	Staticamente irreversibile Ritorno a scatti lenti in caso di vibrazioni Reversibilità dinamica quasi nulla*
1° - 3°	Statically non-reversing No return Low dynamic reversing*	Staticamente irreversibile Nessun ritorno Reversibilità dinamica quasi nulla*

\* We would like to draw your attention on the fact that the total irreversibility cannot be guaranteed, therefore, where it is required, it is recommended to arrange an external braking device.

\* Ci teniamo ad evidenziare che l'irreversibilità totale non può essere garantita pertanto, dove essa è richiesta, è necessario predisporre di un sistema di frenatura esterno al riduttore.

**SQUARE  
WORM GEARBOXES**

The units from Q30 to Q85 are supplied with synthetic oil, providing "long life" lubrication. For mounting position V5 - V6 please contact us.

The units Q11 and Q13 are supplied without lubricant and equipped with a breather, level and drain plugs. User can add mineral oil keeping existing plugs. Should the user wish to fill it with synthetic oil, it is recommended to replace the existing plugs with a closed plug.

The table hereafter must be referred to as for the mounting position pattern and the corresponding oil plugs, if applicable, and related lubricant quantity.

These quantity are only indicative; to ensure correct filling, always refer to the centreline of the sight glass. In some cases, discrepancies, occasionally also substantial, versus the oil quantities listed in the chart may be noticed.

**SQUARE  
RIDUTTORI A VITE SENZA FINE**

I riduttori dal Q30 al Q85 sono forniti con lubrificazione a vita ad olio sintetico. Per posizioni V5 - V6 contattare il nostro servizio tecnico.

I riduttori Q11 e Q13 sono forniti privi di lubrificazione con tappi di sfiato, livello e scarico olio. L'utente può immettere olio minerale mantenendo i tappi esistenti.

Se immetterà olio sintetico, dovrà sostituire i tappi esistenti con altri tipo chiuso.

Nelle tabelle sottostanti vengono rappresentate le posizioni di montaggio, la disposizione dei tappi olio e le relative quantità.

Le quantità di lubrificante sono indicative; per avere il corretto quantitativo di lubrificante si dovrà dare attinenza esclusivamente alla mezzeria del tappo livello o allo sfioramento del foro del tappo, quando presenti.

Tenendo in considerazione quanto appena sostenuto la quantità di lubrificante indicata in tabella può presentare delle differenze, occasionalmente anche rilevanti.

	AGIP Tellium VSF 320			SHELL Omala S4 WE 320		
Q30÷Q85	Q30	Q45	Q50	Q63	Q75	Q85
Q.tà/Q.ty	0.03 Lt	0.09 Lt	0.14 Lt	0.30 Lt	0.40 Lt	1.2 Lt

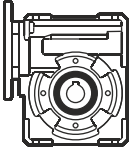
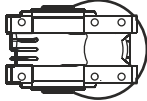
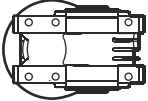
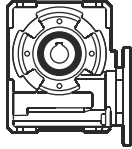
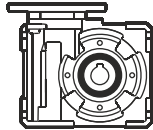
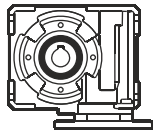
Q11÷Q13	AGIP Blasias 460					
						
	B3	B6	B7	B8	V5	V6
Q11	2.0 Lt	1.5 Lt	1.5 Lt	2.0 Lt	2.0 Lt	2.0 Lt
Q13	4.5 Lt	3.5 Lt	3.5 Lt	3.3 Lt	4.5 Lt	3.3 Lt
Q15	7.0 Lt	5.4 Lt	5.4 Lt	5.1 Lt	7.0 Lt	5.1 Lt

□ These plugs are on the back side. ▼ Filling & Breather ▼ Filling closed △ Emptying ● Level

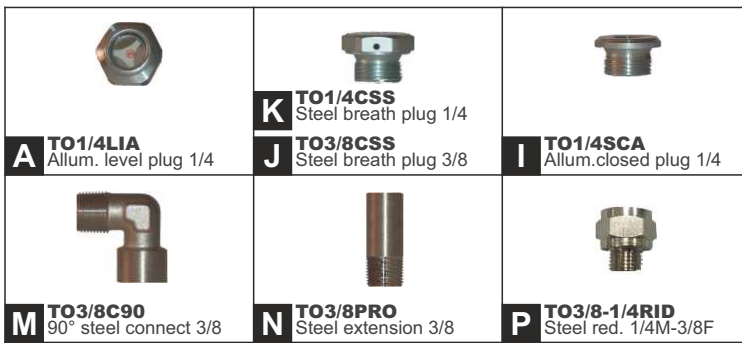

SYNTHETIC OIL	
Code	Description
LUOTVSF320 (Standard)	Synthetic oil 'Telium VSF320'
	Synthetic oil 'Omala S4 WE320'
LUOBLAS150 (Low temperature)	Synthetic oil 'Blasia S 150'
	Synthetic oil 'Omala S4 WE150'

MINERAL OIL	
Code	Description
LUOBLAM460	Mineral oil 'Blasia 460'
	Mineral oil 'Omala S2 G 460'

As standard without oil plugs

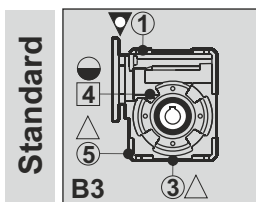

Type	Q30	Q45	Q50	Q63	Q75
Oil q.ty (Lt.)	0.03	0.09	0.14	0.30	0.40
On request	1	-	-	-	K
	3	-		-	
	4	-	-	-	A
	5	-	-	-	

With **mineral oil**, we always need on open oil plug in the higher position to avoid high housing pressure.

With the **synthetic oil** all the oil plugs could be closed.

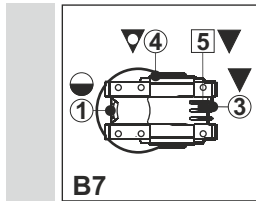

Oil q.ty (Lt.)	0.03	0.09	0.14	0.30	0.40
On request	1	-	-	-	A
	3	-		-	
	4	-	-	-	K
	5	-	-	-	

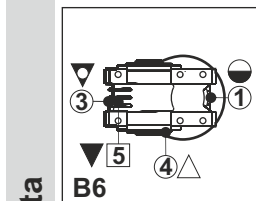

Oil q.ty (Lt.)	0.03	0.09	0.14	0.30	0.40
On request	1	-	-	-	A
	3	-		-	P+M+N+J
	4	-	-	-	
	5	-	-	-	

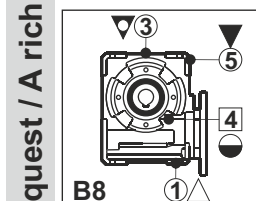

Oil q.ty (Lt.)	0.03	0.09	0.14	0.30	0.40
On request	1	-	-	-	
	3	-		-	K
	4	-	-	-	A
	5	-	-	-	

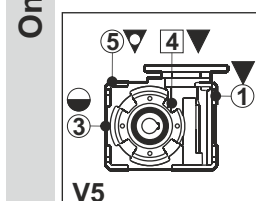

Oil q.ty (Lt.)	0.03	0.09	0.14	0.30	0.40
On request	1	-	-	-	
	3	-		-	A
	4	-	-	-	
	5	-	-	-	K

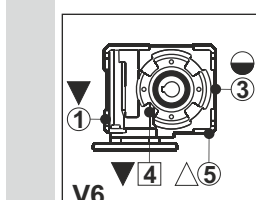

Oil q.ty (Lt.)	0.03	0.09	0.14	0.30	0.40
On request	1	-	-	-	
	3	-		-	A
	4	-	-	-	
	5	-	-	-	

# OIL PLUG POSITIONS - TYPES / POSIZIONE TAPPI OLIO - TIPI

data 17/03/15  
LUB\_VFQ\_01

☐ These plugs are on the back side.    ▼ Filling & Breather    ▼ Filling closed    △ Emptying    ● Level

 <b>B TO3/8LIA</b> Allum. level plug 3/8	 <b>J TO3/8CSS</b> Steel breath plug 3/8	 <b>L TO3/8SCA</b> Allum.closed plug 3/8	
 <b>M TO3/8C90</b> 90° steel connect 3/8	 <b>N TO3/8PRO</b> Steel extension 3/8	<b>Q TOM16*1.5LIA</b> Alluminum Level plug M16*1.5	<b>Q TOM22*1.5LIA</b> Alluminum Level plug M22*1.5
		<b>R TOM16*1.5SCA</b> Alluminum closed plug M16*1.5	<b>R TOM22*1.5SCA</b> Alluminum closed plug M22*1.5
		<b>S TOM16*1.5TPO</b> With valve M16*1.5	<b>S TOM22*1.5TPO</b> With valve M22*1.5

SYNTHETIC OIL	
Code	Description
LUOTVSF320 (Standard)	Synthetic oil 'Telium VSF320'
LUOBLAS150 (Low temperature)	Synthetic oil 'Omala S4 WE320'
	Synthetic oil 'Blasia S 150'
	Synthetic oil 'Omala S4 WE150'

MINERAL OIL	
Code	Description
LUOBLAM460	Mineral oil 'Blasia 460'
	Mineral oil 'Omala S2 G 460'

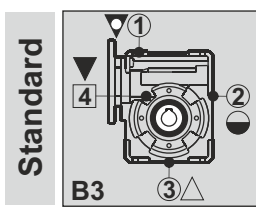

Type	Q85	Q11
Oil q.ty (Lt.)	1.20	2.00
Plugs	On request	Standard
①	J	J
②	B	B
③	L	L
④	L	L

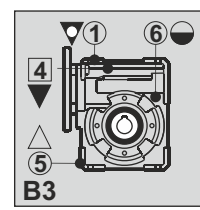

Type	Q13	Q15
Oil q.ty (Lt.)	4.50	7.00
Plugs	Standard	Standard
①	S	S
④	R	R
⑤	R	R
⑥	Q	Q

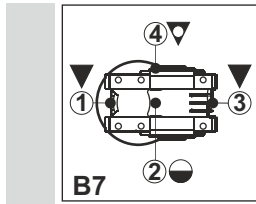

Type	Q85	Q11
Oil q.ty (Lt.)	1.20	1.35
Plugs	On request	Standard
①	L	L
②	B	B
③	L	L
④	J	J

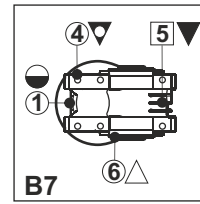

Type	Q13	Q15
Oil q.ty (Lt.)	3.50	5.40
Plugs	Standard	Standard
①	Q	Q
④	S	S
⑤	R	R
⑥	R	R

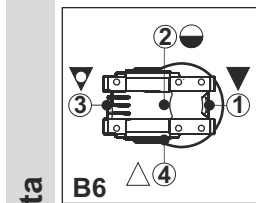

Type	Q85	Q11
Oil q.ty (Lt.)	1.20	1.35
Plugs	On request	Standard
①	L	L
②	B	B
③	M+N+J	M+N+J
④	L	L

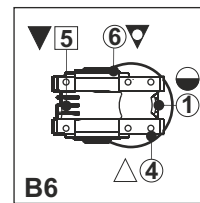

Type	Q13	Q15
Oil q.ty (Lt.)	3.50	5.40
Plugs	Standard	Standard
①	Q	Q
④	R	R
⑤	R	R
⑥	S	S

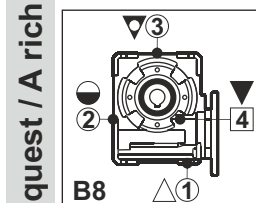

Type	Q85	Q11
Oil q.ty (Lt.)	1.20	2.00
Plugs	On request	Standard
①	L	L
②	B	B
③	J	J
④	L	L

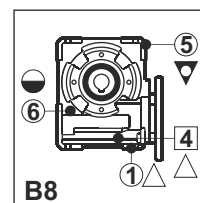

Type	Q13	Q15
Oil q.ty (Lt.)	3.30	5.10
Plugs	Standard	Standard
①	R	R
④	R	R
⑤	S	S
⑥	Q	Q

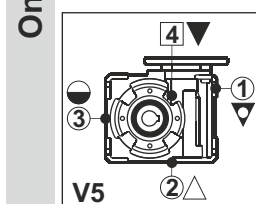

Type	Q85	Q11
Oil q.ty (Lt.)	1.20	2.00
Plugs	On request	Standard
①	J	J
②	L	L
③	B	B
④	L	L

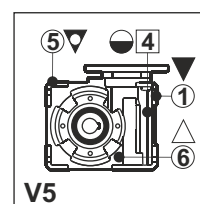

Type	Q13	Q15
Oil q.ty (Lt.)	4.50	7.00
Plugs	Standard	Standard
①	R	R
④	Q	Q
⑤	S	S
⑥	R	R

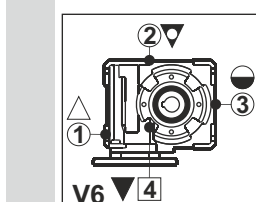

Type	Q85	Q11
Oil q.ty (Lt.)	1.20	2.00
Plugs	On request	Standard
①	L	L
②	J	J
③	B	B
④	L	L

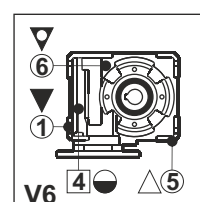

Type	Q13	Q15
Oil q.ty (Lt.)	3.30	5.10
Plugs	Standard	Standard
①	R	R
④	Q	Q
⑤	R	R
⑥	S	S

**SQUARE  
HELICAL WORMBOXES**

The units from P4Q to P8Q are supplied with synthetic oil, providing "long life" lubrication. For mounting position V5 - V6 please contact us.

P4Q and P5Q gearboxes are supplied only with common lubrication.

The units P1Q and Q13+511, 11Q and 13Q are supplied without lubricant and equipped with a breather, level and drain plugs. User can add mineral oil keeping existing plugs. Should the user wish to fill it with synthetic oil, it is recommended to replace the existing plugs with a closed plug.

The table hereafter must be referred to as for the mounting position pattern and the corresponding oil plugs, if applicable, and related lubricant quantity.

These quantity are only indicative; to ensure correct filling, always refer to the centreline of the sight glass. In some cases, discrepancies, occasionally also substantial, versus the oil quantities listed in the chart may be noticed.

**SQUARE  
RIDUTTORI CON PRECOPPIA**

I riduttori dal P4Q al P8Q sono forniti con lubrificazione a vita ad olio sintetico. Per posizioni V5 - V6 contattare il nostro servizio tecnico.

I riduttori P4Q e P5Q sono forniti soltanto con lubrificazione comune.

I riduttori P1Q e Q13+511, 11Q e il Q13 sono forniti privi di lubrificazione con tappi di sfiato, livello e scarico olio. L'utente può immettere olio minerale mantenendo i tappi esistenti.

Se immetterà olio sintetico, dovrà sostituire i tappi esistenti con altri tipo chiuso. Nelle tabelle sottostanti vengono rappresentate le posizioni di montaggio, la disposizione dei tappi olio e le relative quantità.

Le quantità di lubrificante sono indicative; per avere il corretto quantitativo di lubrificante si dovrà dare attinenza esclusivamente alla mezzeria del tappo livello o allo sfioramento del foro del tappo, quando presenti. Tenendo in considerazione quanto appena sostenuto la quantità di lubrificante indicata in tabella può presentare delle differenze, occasionalmente anche rilevanti.

<b>P4Q+P8Q</b> 	<b>AGIP</b> Tellium VSF 320				<b>SHELL</b> Omala S4 WE 320					
	<b>P4Q</b>		<b>P5Q</b>		<b>P6Q</b>		<b>P7Q</b>		<b>P8Q</b>	
	A	B	A	B	A	B	A	B	A	B
<b>Separate</b> lubrication Q.tà/Q.ty B3-V5-V6	-	-	-	-	0.30 Lt	0.08 Lt	0.40 Lt	0.14 Lt	1.20 Lt	0.14 Lt
<b>Common</b> lubrication Q.tà/Q.ty B6-B7-B8	-	-	-	-	0.35 Lt		0.65 Lt		1.00 Lt	
<b>Common</b> lubrication for all position	0.17 Lt		0.26 Lt		-		-		-	

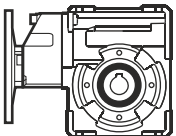
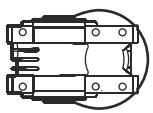
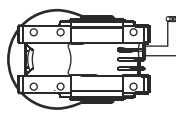
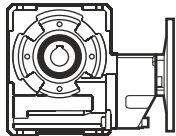
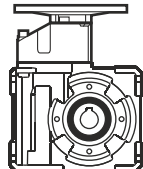
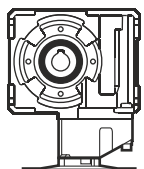
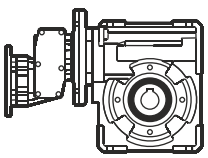
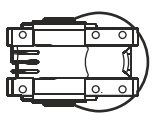
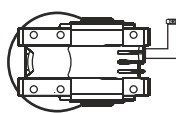
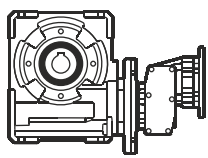
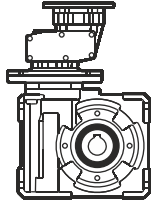
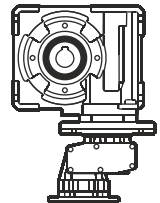
<b>P1Q÷Q13+511</b>	<b>AGIP</b> Blasias 460					
 <b>B3</b>	 <b>B6</b>	 <b>B7</b>	 <b>B8</b>	 <b>V5</b>	 <b>V6</b>	
<b>P1Q</b> 2.0 / 0.14 Lt	1.5 / 0.14 Lt	1.5 / 0.14 Lt	2.0 / 0.14 Lt	2.0 / 0.14 Lt	2.0 / 0.14 Lt	
 <b>B3</b>	 <b>B6</b>	 <b>B7</b>	 <b>B8</b>	 <b>V5</b>	 <b>V6</b>	
<b>Q13 + 511</b> 4.5 / 0.14 Lt	3.5 / 0.14 Lt	3.5 / 0.14 Lt	3.3 / 0.14 Lt	4.5 / 0.14 Lt	3.3 / 0.14 Lt	



□ These plugs are on the back side. ▼ Filling & Breather ▼ Filling closed △ Emptying ● Level

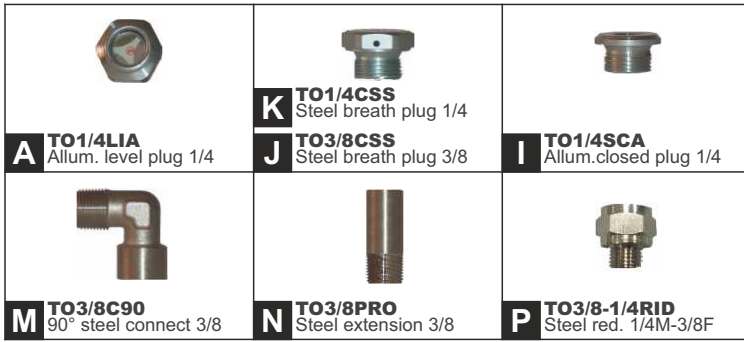

SYNTHETIC OIL	
Code	Description
LUOTVSF320 (Standard)	Synthetic oil 'Telium VSF320' Synthetic oil 'Omala S4 WE320'
LUOBLAS150 (Low temperature)	Synthetic oil 'Blasia S 150' Synthetic oil 'Omala S4 WE150'

MINERAL OIL	
Code	Description
LUOBLAM460	Mineral oil 'Blasia 460' Mineral oil 'Omala S2 G 460'

As standard without oil plugs

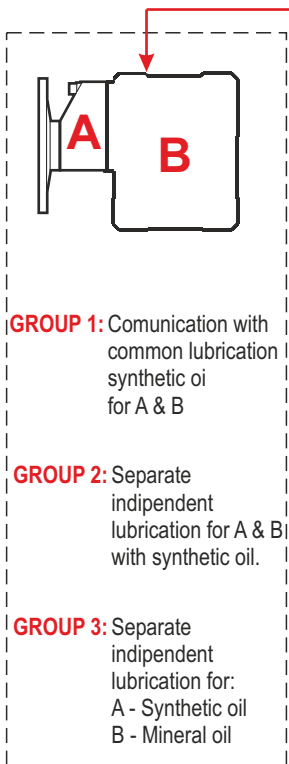

Type	GROUP 1		GROUP 2	
	P4Q	P5Q	P6Q	P7Q
Oil q.ty (Lt.) B			0.30	0.40
Oil q.ty (Lt.) A	0.17	0.26	0.08	0.14
On request	① -	③	④ -	⑤
	② -	④ -	⑤ -	⑥ -

Type	GROUP 1			
	Oil q.ty (Lt.) B	0.17	0.26	0.35
Oil q.ty (Lt.) A				
On request	① -	③	④ -	⑤
	② -	④ -	⑤ -	⑥ -

Type	GROUP 1			
	Oil q.ty (Lt.) B	0.17	0.26	0.35
Oil q.ty (Lt.) A				
On request	① -	③	④ -	⑤
	② -	④ -	⑤ -	⑥ -

Type	GROUP 1			
	Oil q.ty (Lt.) B	0.17	0.26	0.35
Oil q.ty (Lt.) A				
On request	① -	③	④ -	⑤
	② -	④ -	⑤ -	⑥ -

Type	GROUP 1		GROUP 2	
	P4Q	P5Q	P6Q	P7Q
Oil q.ty (Lt.) B			0.30	0.40
Oil q.ty (Lt.) A	0.17	0.26	0.08	0.14
On request	① -	③	④ -	⑤
	② -	④ -	⑤ -	⑥ -

Type	GROUP 1		GROUP 2	
	P4Q	P5Q	P6Q	P7Q
Oil q.ty (Lt.) B			0.30	0.40
Oil q.ty (Lt.) A	0.17	0.26	0.08	0.14
On request	① -	③	④ -	⑤
	② -	④ -	⑤ -	⑥ -





With **mineral oil**, we always need on open oil plug in the higher position to avoid high housing pressure.

With the **synthetic oil** all the oil plugs could be closed.

# OIL PLUG POSITIONS - TYPES / POSIZIONE TAPPI OLIO - TIPI

data 17/03/15  
LUB\_VFQ\_02

□ These plugs are on the back side. ▼ Filling & Breather ▼ Filling closed △ Emptying ● Level

 <b>B TO3/8LIA</b> Allum. level plug 3/8	 <b>J TO3/8CSS</b> Steel breath plug 3/8	 <b>L TO3/8SCA</b> Allum.closed plug 3/8
 <b>M TO3/8C90</b> 90° steel connect 3/8	 <b>N TO3/8PRO</b> Steel extension 3/8	<b>Q TOM16*1.5LIA</b> Alluminum Level plug M16*1.5 <b>R TOM16*1.5SCA</b> Alluminum closed plug M16*1.5 <b>S TOM16*1.5TPO</b> With valve M16*1.5

SYNTHETIC OIL	
Code	Description
LUOTVSF320 (Standard)	Synthetic oil 'Telium VSF320' Synthetic oil 'Omala S4 WE320'
LUOBLAS150 (Low temperature)	Synthetic oil 'Blasia S 150' Synthetic oil 'Omala S4 WE150'

MINERAL OIL	
Code	Description
LUOBLAM460	Mineral oil 'Blasia 460' Mineral oil 'Omala S2 G 460'

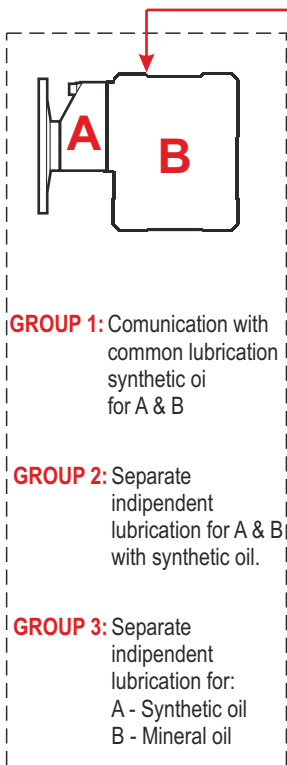

Type	GROUP 2	GROUP 3
	P8Q	P1Q
Oil q.ty (Lt) <b>B</b>	1.20	2.00
Oil q.ty (Lt) <b>A</b>	0.14	0.14
Plugs	On request	Standard
①	J	J
②	B	B
③	L	L
④	L	L

Type	GROUP 1	GROUP 3
	Oil q.ty (Lt) <b>B</b>	1.00
Oil q.ty (Lt) <b>A</b>		0.14
Plugs	On request	Standard
①	L	L
②	B	B
③	L	L
④	J	J

Type	GROUP 1	GROUP 3
	Oil q.ty (Lt) <b>B</b>	1.00
Oil q.ty (Lt) <b>A</b>		0.14
Plugs	On request	Standard
①	L	L
②	B	B
③	M+N+J	M+N+J
④	L	L

Type	GROUP 1	GROUP 3
	Oil q.ty (Lt) <b>B</b>	1.00
Oil q.ty (Lt) <b>A</b>		0.14
Plugs	On request	Standard
①	L	L
②	B	B
③	J	J
④	L	L

  

Type	GROUP 2	GROUP 3
	Oil q.ty (Lt) <b>B</b>	1.20
Oil q.ty (Lt) <b>A</b>	0.14	0.14
Plugs	On request	Standard
①	J	J
②	L	L
③	B	B
④	L	L

  

Type	GROUP 1	GROUP 3
	Oil q.ty (Lt) <b>B</b>	1.20
Oil q.ty (Lt) <b>A</b>	0.14	0.14
Plugs	On request	Standard
①	L	L
②	J	J
③	B	B
④	L	L

On request / A richiesta

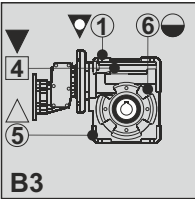
GROUP 3	
	<b>Q13+511A</b> 4.50 0.14 Standard ① S ④ R ⑤ R ⑥ Q

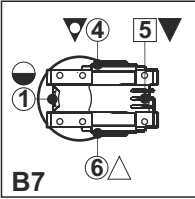
GROUP 3	
	3.50 0.14 Standard ① Q ④ S ⑤ R ⑥ R

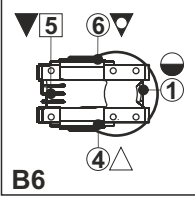
GROUP 3	
	3.50 0.14 Standard ① Q ④ R ⑤ R ⑥ S

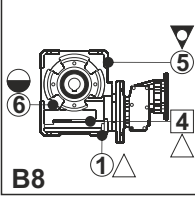
GROUP 3	
	3.30 0.14 Standard ① R ④ R ⑤ S ⑥ Q

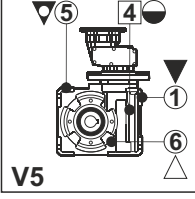
GROUP 3	
	4.50 0.14 Standard ① R ④ Q ⑤ S ⑥ R

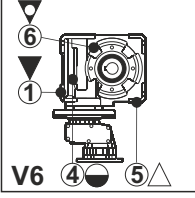
GROUP 3	
	3.30 0.14 Standard ① R ④ Q ⑤ R ⑥ S

**SQUARE  
DOUBLE WORMBOXES**

The units from 43Q to 84Q are supplied with synthetic oil, providing "long life" lubrication. For mounting position V5 - V6 please contact us.

The unit 15Q , 11Q is supplied without lubricant and equipped with a breather, level and drain plugs. User can add mineral oil keeping existing plugs. Should the user wish to fill it with synthetic oil, it is recommended to replace the existing plugs with a closed plug.

The table hereafter must be referred to as for the mounting position pattern and the corresponding oil plugs, if applicable, and related lubricant quantity.

These quantity are only indicative; to ensure correct filling, always refer to the centreline of the sight glass.

In some cases, discrepancies, occasionally also substantial, versus the oil quantities listed in the chart may be noticed.

**SQUARE  
RIDUTTORI A VITE SENZA FINE**

I riduttori dal 43Q al 84Q sono forniti con lubrificazione a vita ad olio sintetico . Per posizioni V5 - V6 contattare il nostro servizio tecnico.

Il riduttore 15Q , 11Q è fornito privo di lubrificazione con tappi di sfiato, livello e scarico olio. L'utente può immettere olio minerale mantenendo i tappi esistenti.

Se immetterà olio sintetico, dovrà sostituire i tappi esistenti con altri tipo chiuso.

Nelle tabelle sottostanti vengono rappresentate le posizioni di montaggio, la disposizione dei tappi olio e le relative quantità.

Le quantità di lubrificante sono indicative; per avere il corretto quantitativo di lubrificante si dovrà dare attinenza esclusivamente alla mezzeria del tappo livello o allo sfioramento del foro del tappo, quando presenti.

Tenendo in considerazione quanto appena sostenuto la quantità di lubrificante indicata in tabella può presentare delle differenze, occasionalmente anche rilevanti.

	AGIP Tellium VSF 320			SHELL Omala S4 WE 320		
43Q+84Q	43Q	53Q	63Q	64Q	74Q	84Q
Q.tà	0.09 / 0.03 Lt	0.14 / 0.03 Lt	0.30 / 0.03 Lt	0.30 / 0.03 Lt	0.40 / 0.09 Lt	1.2 / 0.09 Lt

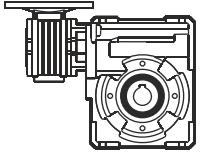
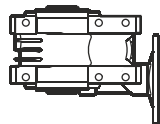
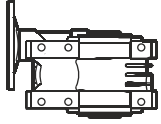
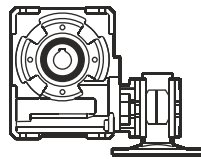
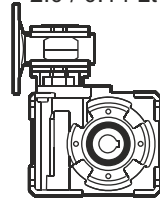
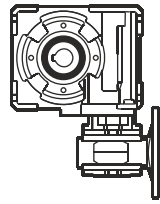
15Q	AGIP Blasias 460					
	B3	B6	B7	B8	V5	V6
	2.0 / 0.14 Lt	1.5 / 0.14 Lt	1.5 / 0.14 Lt	2.0 / 0.14 Lt	2.0 / 0.14 Lt	2.0 / 0.14 Lt
						

□ These plugs are on the back side. ▼ Filling & Breather ▼ Filling closed △ Emptying ● Level

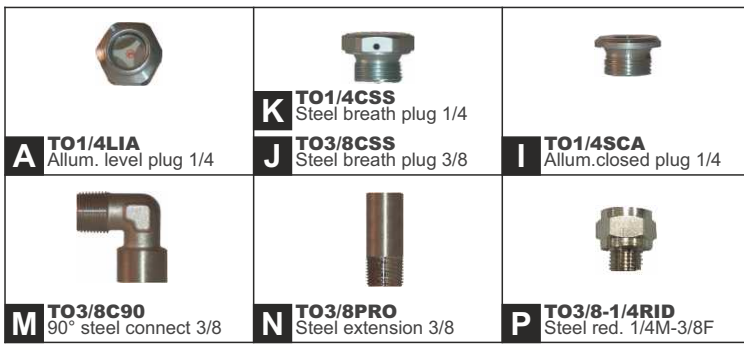

SYNTHETIC OIL	
Code	Description
LUOTVSF320 (Standard)	Synthetic oil 'Telium VSF320' Synthetic oil 'Omala S4 WE320'
LUOBLAS150 (Low temperature)	Synthetic oil 'Blasia S 150' Synthetic oil 'Omala S4 WE150'

MINERAL OIL	
Code	Description
LUOBLAM460	Mineral oil 'Blasia 460' Mineral oil 'Omala S2 G 460'

As standard without oil plugs

Standard

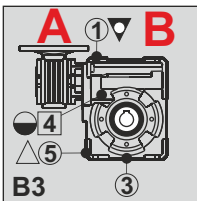

Type	43Q	53Q	63Q	64Q	74Q
Oil q.ty (Lt.) B	0.09	0.14	0.30	0.30	0.40
Oil q.ty (Lt.) A	0.03	0.03	0.03	0.09	0.09
On request	1	-		K	
	3				
	4	-		A	
	5	-			

With **mineral oil**, we always need an open oil plug in the higher position to avoid high housing pressure.

With the **synthetic oil** all the oil plugs could be closed.

On request / A richiesta

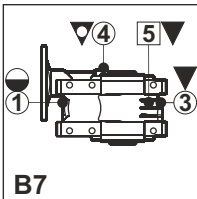

Oil q.ty (Lt.) B	0.09	0.14	0.30	0.30	0.40
Oil q.ty (Lt.) A	0.03	0.03	0.03	0.09	0.09
On request	1	-		A	
	3				
	4	-		K	
	5	-			

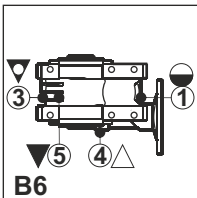

Oil q.ty (Lt.) B	0.09	0.14	0.30	0.30	0.40
Oil q.ty (Lt.) A	0.03	0.03	0.03	0.09	0.09
On request	1	-		A	
	3			P+M+N+J	
	4	-			
	5	-			

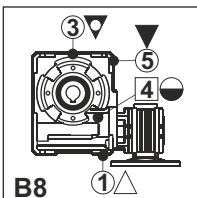

Oil q.ty (Lt.) B	0.09	0.14	0.30	0.30	0.40
Oil q.ty (Lt.) A	0.03	0.03	0.03	0.09	0.09
On request	1	-			
	3			K	
	4	-		A	
	5	-			

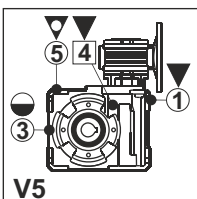

Oil q.ty (Lt.) B	0.09	0.14	0.30	0.30	0.40
Oil q.ty (Lt.) A	0.03	0.03	0.03	0.09	0.09
On request	1	-			
	3			A	
	4	-			
	5	-		K	

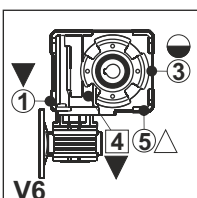

Oil q.ty (Lt.) B	0.09	0.14	0.30	0.30	0.40
Oil q.ty (Lt.) A	0.03	0.03	0.03	0.09	0.09
On request	1	-			
	3			A	
	4	-			
	5	-			

□ These plugs are on the back side. ▼ Filling & Breather ▼ Filling closed △ Emptying ● Level



SYNTHETIC OIL	
Code	Description
LUOTVSF320 (Standard)	Synthetic oil 'Telium VSF320' Synthetic oil 'Omala S4 WE320'
LUOBLAS150 (Low temperature)	Synthetic oil 'Blasia S 150' Synthetic oil 'Omala S4 WE150'

MINERAL OIL	
Code	Description
LUOBLAM460	Mineral oil 'Blasia 460' Mineral oil 'Omala S2 G 460'

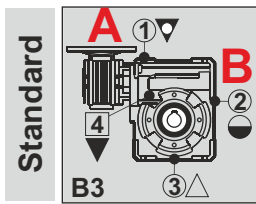

Type	84Q	15Q
Oil q.ty (Lt.) <b>B</b>	1.20	2.00 Mineral Oil
Oil q.ty (Lt.) <b>A</b>	0.09	0.14 Synth. Oil
Plugs	On request	Standard
①	J	J
②	B	B
③	L	L
④	L	L

Only for 15Q (Q11+050)  
lubrication Q11 with mineral oil  
050 with synthetic oil

With **mineral oil**, we always need on open oil plug in the higher position to avoid high housing pressure.

With the **synthetic oil** all the oil plugs could be closed.

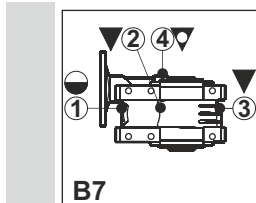

Oil q.ty (Lt.) <b>B</b>	1.20	1.50 Mineral Oil
Oil q.ty (Lt.) <b>A</b>	0.09	0.14 Synth. Oil
Plugs	On request	Standard
①	L	J
②	B	B
③	L	L
④	J	J

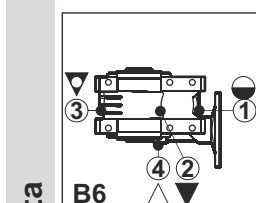

Oil q.ty (Lt.) <b>B</b>	1.20	1.50 Mineral Oil
Oil q.ty (Lt.) <b>A</b>	0.09	0.14 Synth. Oil
Plugs	On request	Standard
①	L	L
②	B	B
③	M+N+J	M+N+J
④	L	L

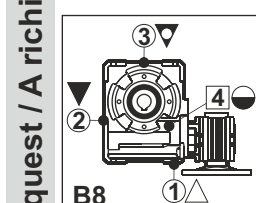

Oil q.ty (Lt.) <b>B</b>	1.20	2.00 Mineral Oil
Oil q.ty (Lt.) <b>A</b>	0.09	0.14 Synth. Oil
Plugs	On request	Standard
①	L	L
②	B	B
③	J	J
④	L	L

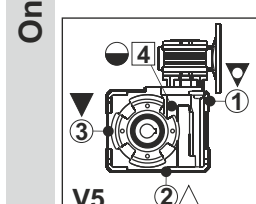

Oil q.ty (Lt.) <b>B</b>	1.20	2.00 Mineral Oil
Oil q.ty (Lt.) <b>A</b>	0.09	0.14 Synth. Oil
Plugs	On request	Standard
①	J	J
②	L	L
③	B	B
④	L	L

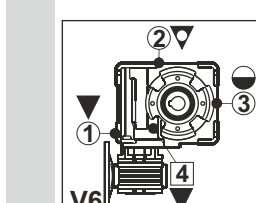

Oil q.ty (Lt.) <b>B</b>	1.20	2.00 Mineral Oil
Oil q.ty (Lt.) <b>A</b>	0.09	0.14 Synth. Oil
Plugs	On request	Standard
①	L	L
②	J	J
③	B	B
④	L	L









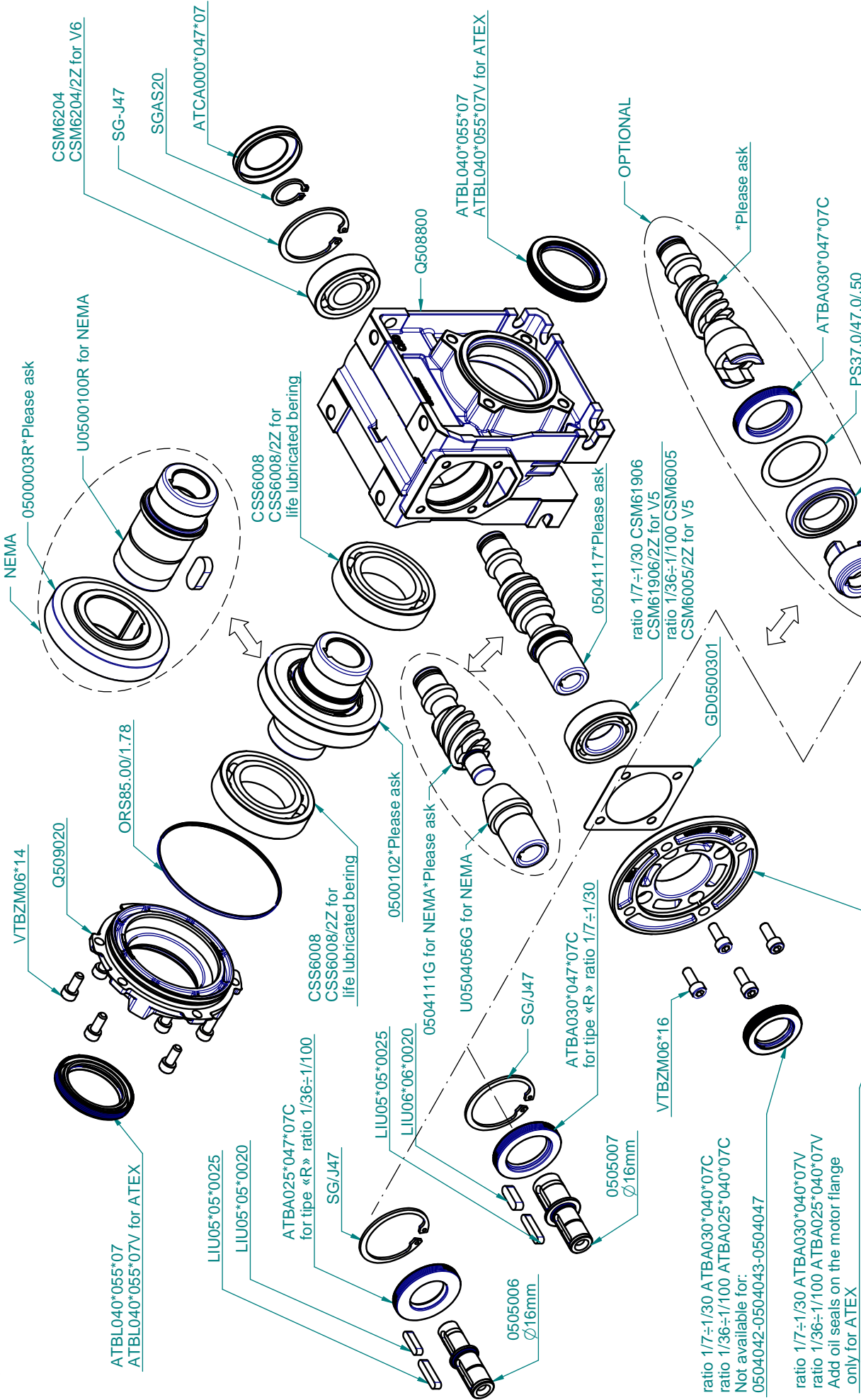

Code	Mot.	**Motor fixing screws
0504041	63 B5	n°4 M8x30 T.E.
0504042	71 B5	n°4 M8x30 T.E.
0504043	80 B5	n°4 M10x35 T.E.
C404049	56 B14	n°4 M5x16 T.E.
0504047	63 B14	n°3 M5x16 T.C.E.I.
0504045	71 B14	n°4 M6x20 T.E.
0504046	80 B14	n°4 M6x20 T.E.
U0504041	56C	-

\* (Please Ask) Depending on the ratio

Order from parts required from gearbox size Q50 ratio \_\_\_\_\_

From \_\_\_\_\_ Date \_\_\_\_\_ / \_\_\_\_\_ / \_\_\_\_\_

Parts	Qty	Description



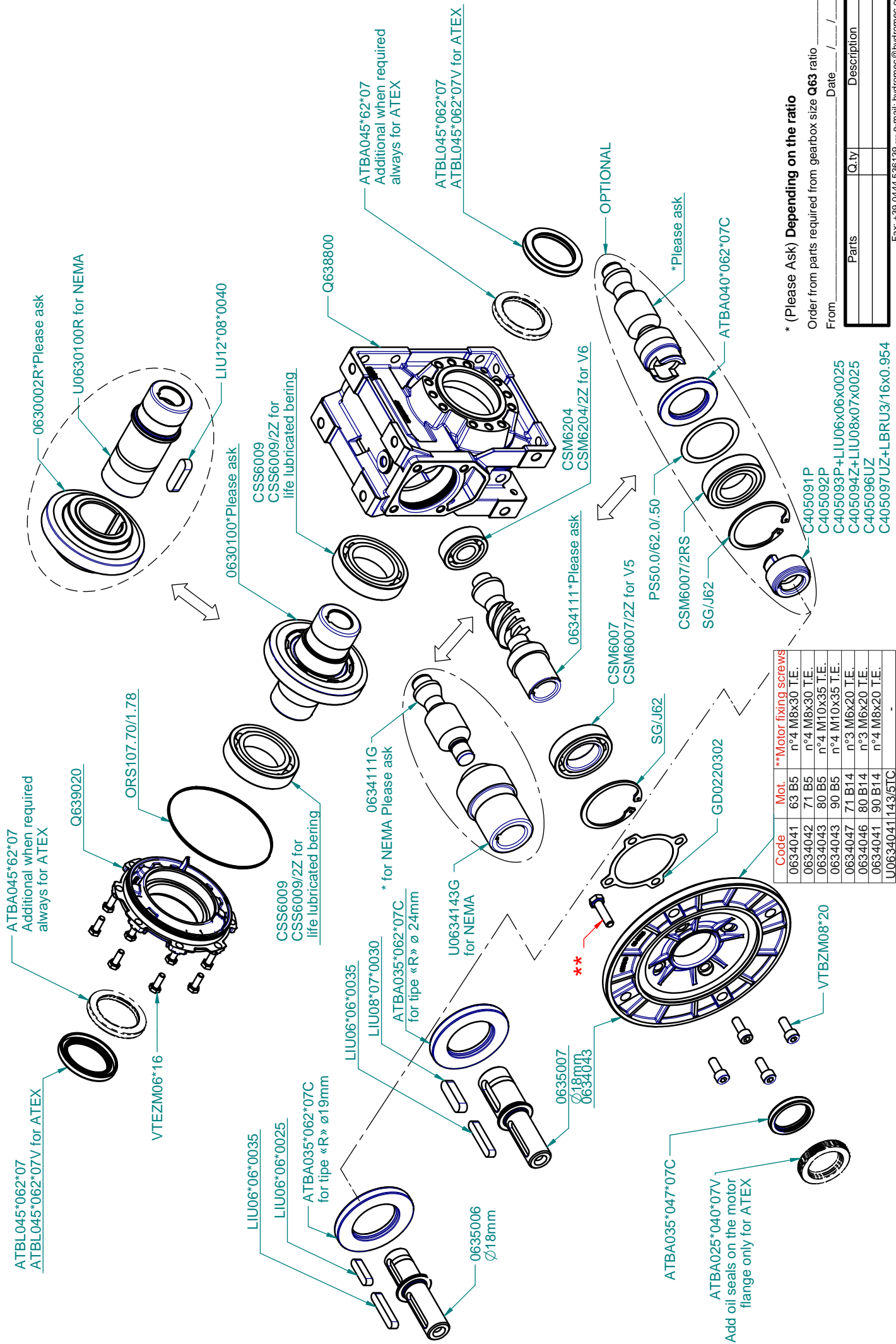

Code	Mot.	**Motor fixing screws
0634041	63 B5	n°4 M8x30 T.E.
0634042	71 B5	n°4 M8x30 T.E.
0634043	80 B5	n°4 M10x35 T.E.
0634043	90 B5	n°4 M10x35 T.E.
0634047	71 B14	n°3 M6x20 T.E.
0634046	80 B14	n°3 M6x20 T.E.
0634041	90 B14	n°4 M8x20 T.E.
U0634041	143/5TC	-

\* (Please Ask) Depending on the ratio

Order from parts required from gearbox size Q63 ratio

From \_\_\_\_\_ Date \_\_\_\_\_

Parts	Q.ty	Description

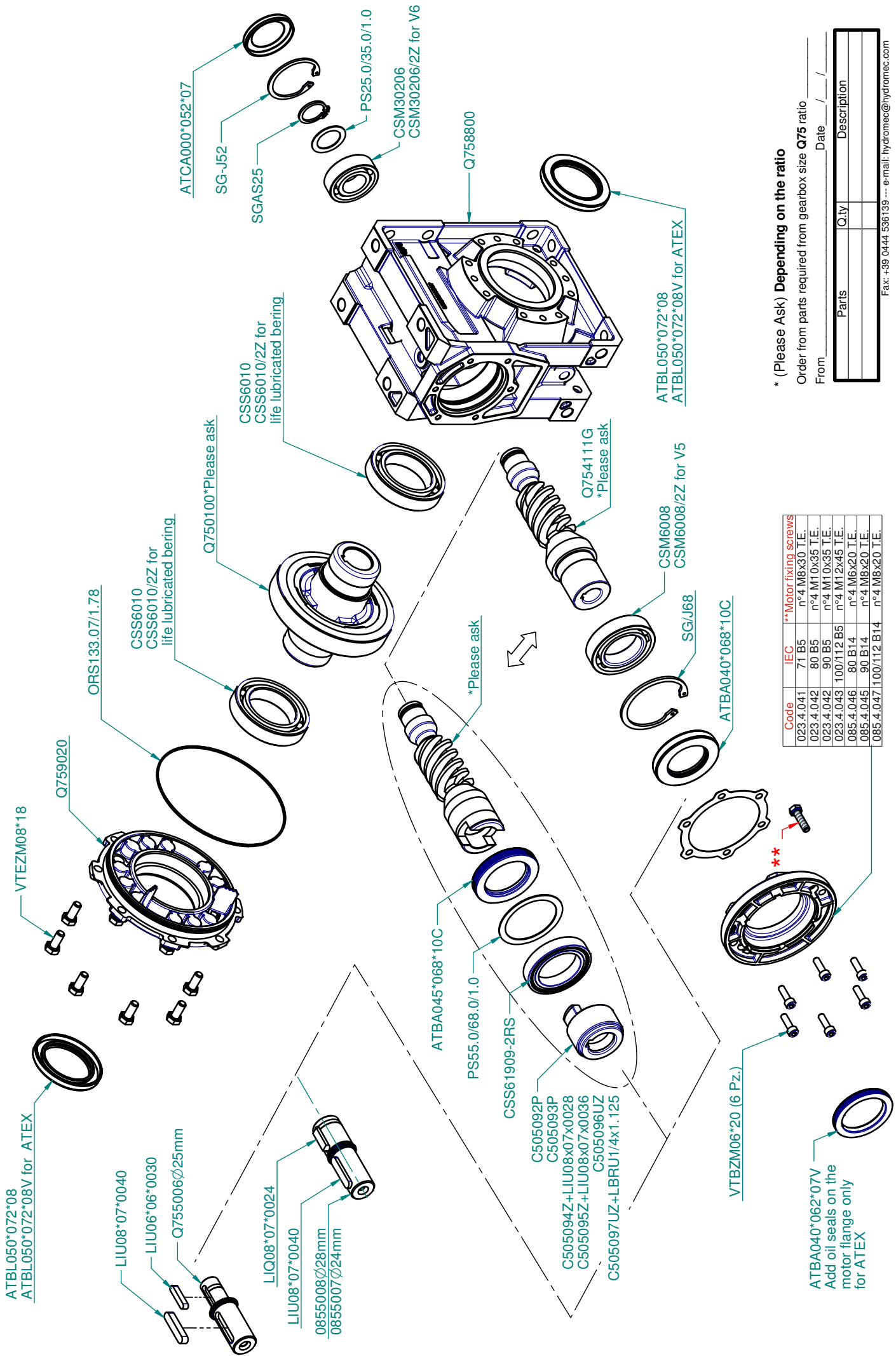

\* (Please Ask) Depending on the ratio

Order from parts required from gearbox size Q75 ratio

From \_\_\_\_\_ Date \_\_\_\_\_

Parts	Qty	Description

Code	IEC	** Motor fixing screws
023.4.041	71 B5	n°4 M8x30 T.E.
023.4.042	80 B5	n°4 M10x35 T.E.
023.4.042	90 B5	n°4 M10x35 T.E.
023.4.043	100/112 B5	n°4 M12x45 T.E.
085.4.046	80 B14	n°4 M6x20 T.E.
085.4.045	90 B14	n°4 M8x20 T.E.
085.4.047	100/112 B14	n°4 M8x20 T.E.

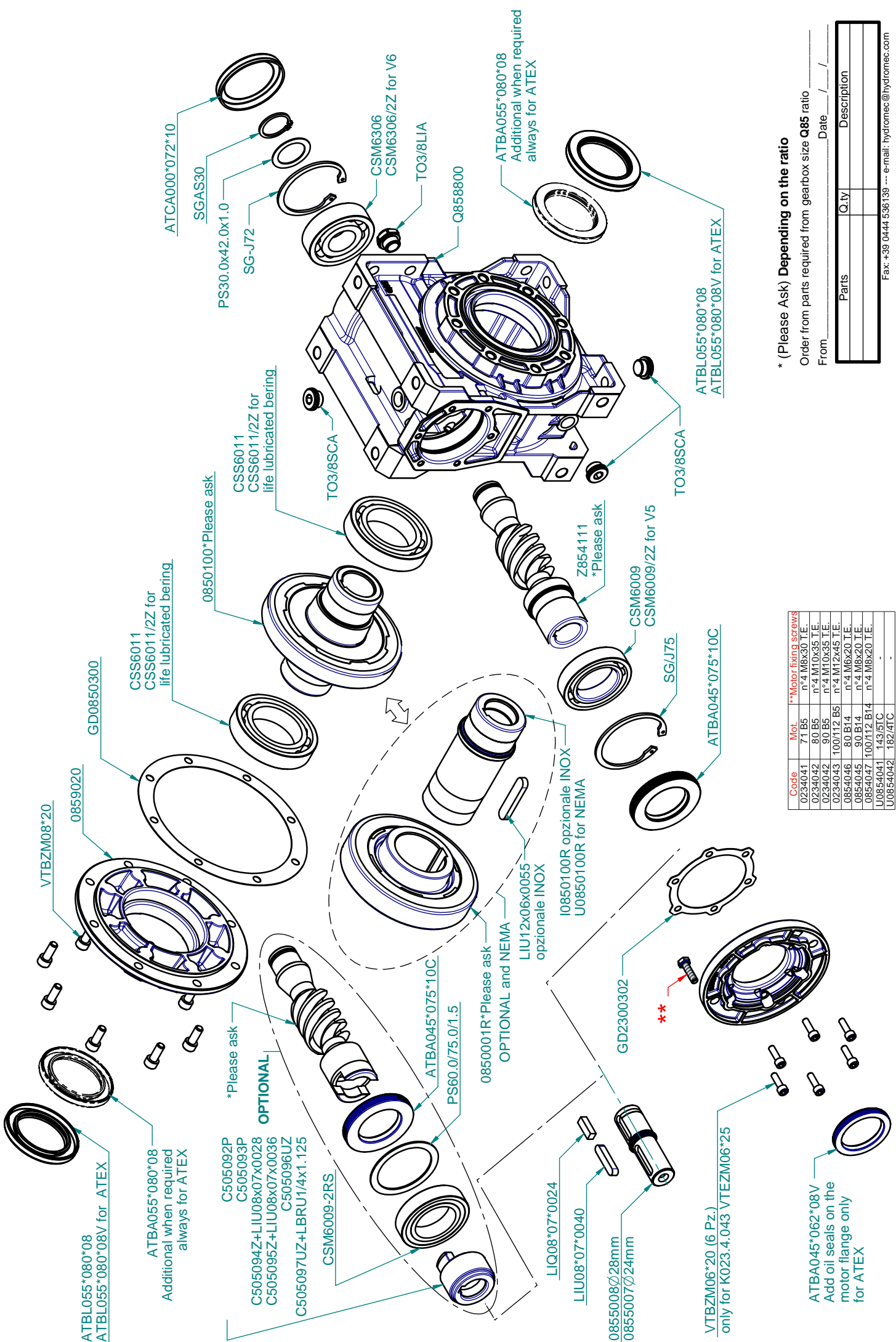

Code	Mot.	**Motor fixing screws
0234041	71 B5	n°4 M8x30 T.E.
0234042	80 B5	n°4 M10x35 T.E.
0234042	90 B5	n°4 M10x35 T.E.
0234043	100/112 B5	n°4 M12x45 T.E.
0854046	80 B14	n°4 M6x20 T.E.
0854045	90 B14	n°4 M6x20 T.E.
0854047	100/112 B14	n°4 M8x20 T.E.
U0854041	143/5TC	-
U0854042	182/4TC	-

\* (Please Ask) Depending on the ratio

Order from parts required from gearbox size Q85 ratio

From: \_\_\_\_\_ Date: \_\_\_\_/\_\_\_\_/\_\_\_\_

Parts	Q.ty	Description

Fax: +39 0444 536139 ---- e-mail: hydromec@hydromec.com



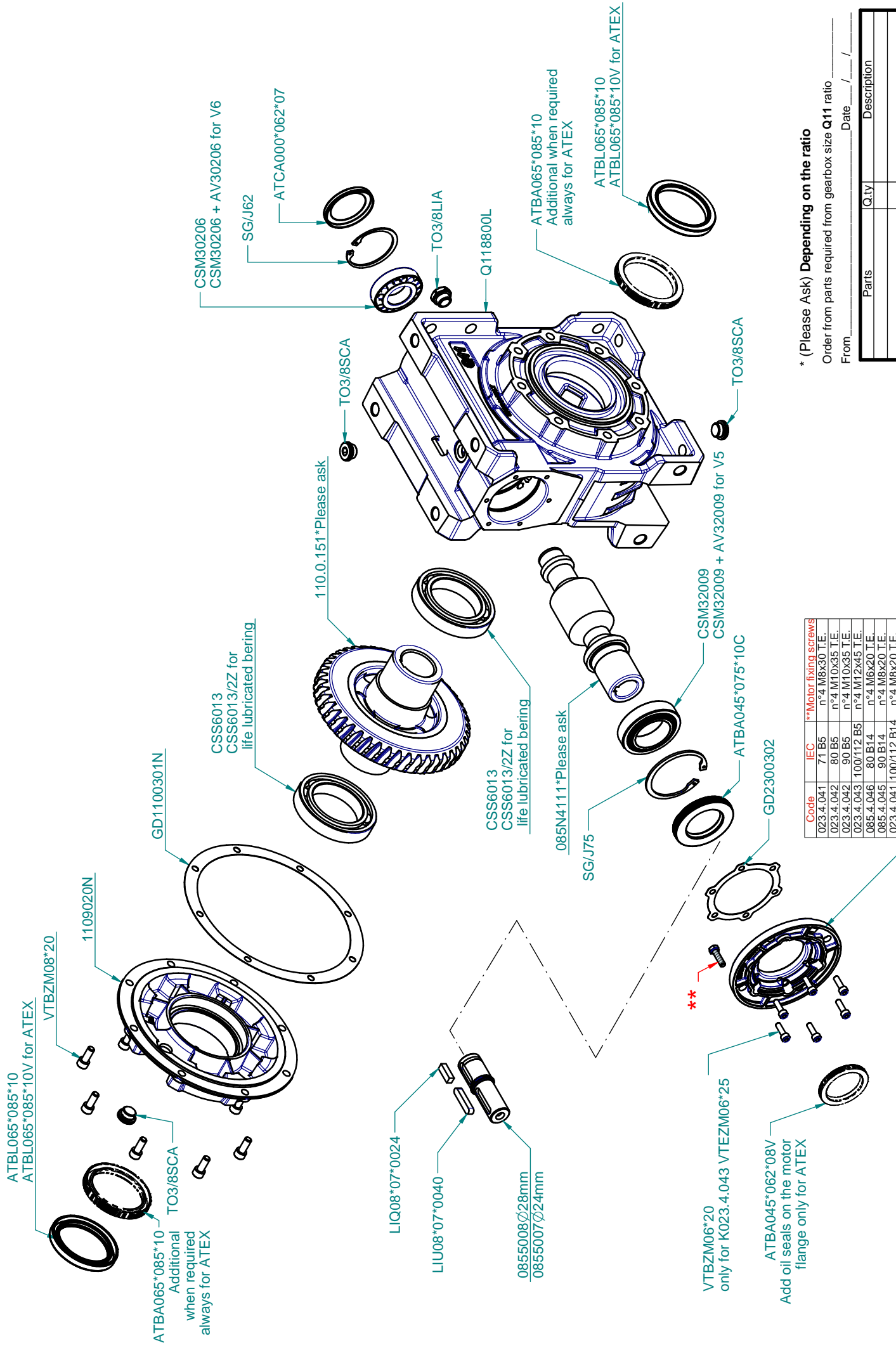

Code	IEC	**Motor fixing screws
023.4.041	71 B5	n°4 M8x30 T.E.
023.4.042	80 B5	n°4 M10x35 T.E.
023.4.042	90 B5	n°4 M10x35 T.E.
023.4.043	100/112 B5	n°4 M12x45 T.E.
085.4.046	80 B14	n°4 M6x20 T.E.
085.4.045	90 B14	n°4 M8x20 T.E.
023.4.041	100/112 B14	n°4 M8x20 T.E.

\* (Please Ask) Depending on the ratio

Order from parts required from gearbox size Q11 ratio \_\_\_\_\_  
From \_\_\_\_\_ Date \_\_\_\_/\_\_\_\_/\_\_\_\_

Parts	Q.ty	Description

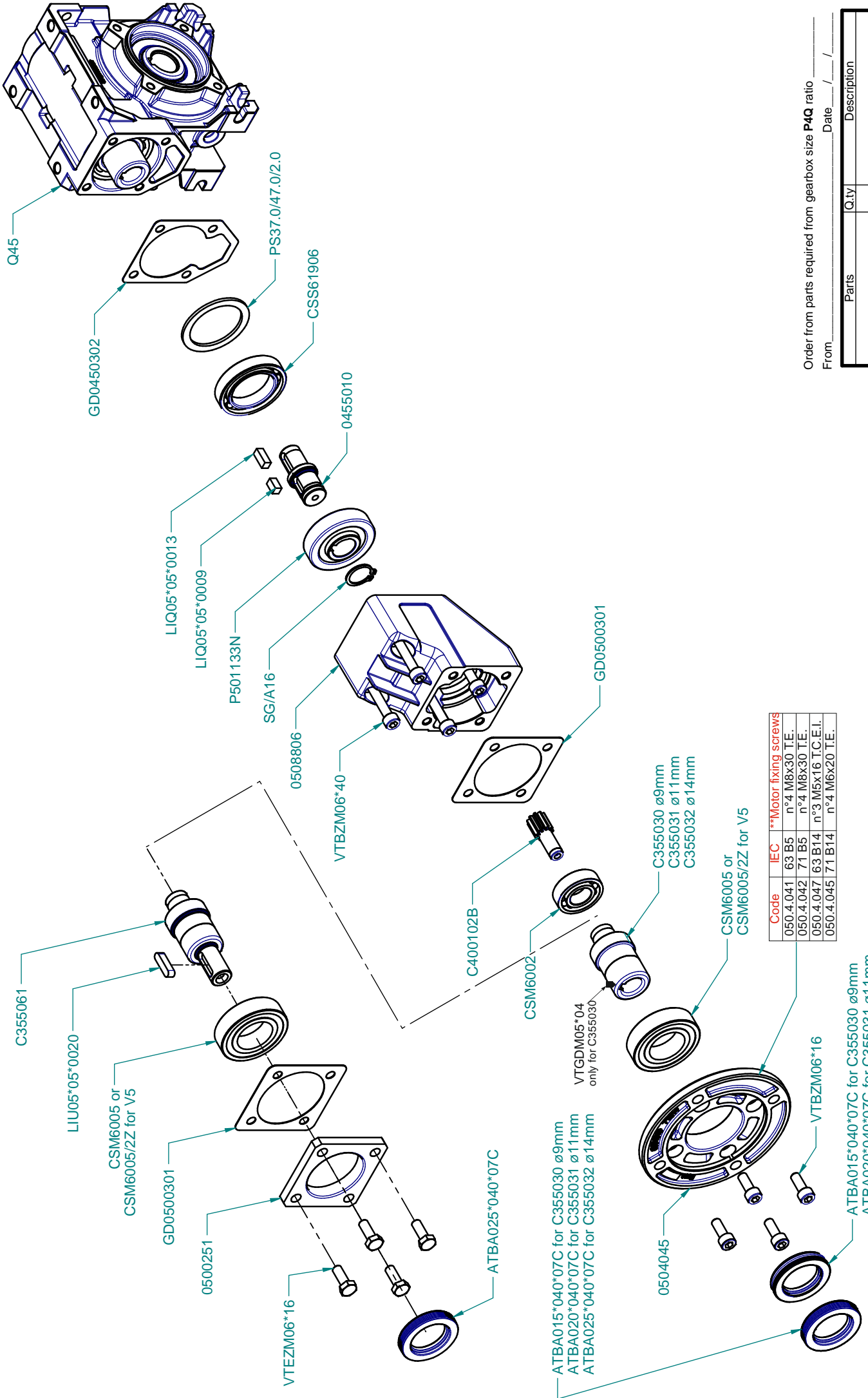

Code	IEC	**Motor fixing screws
050.4.041	63 B5	n°4 M8x30 T.E.
050.4.042	71 B5	n°4 M8x30 T.E.
050.4.047	63 B14	n°3 M5x16 T.C.E.I.
050.4.045	71 B14	n°4 M6x20 T.E.

Order from parts required from gearbox size **P4Q** ratio \_\_\_\_\_  
 From \_\_\_\_\_ Date \_\_\_\_/\_\_\_\_/\_\_\_\_

Parts	Q.ty	Description

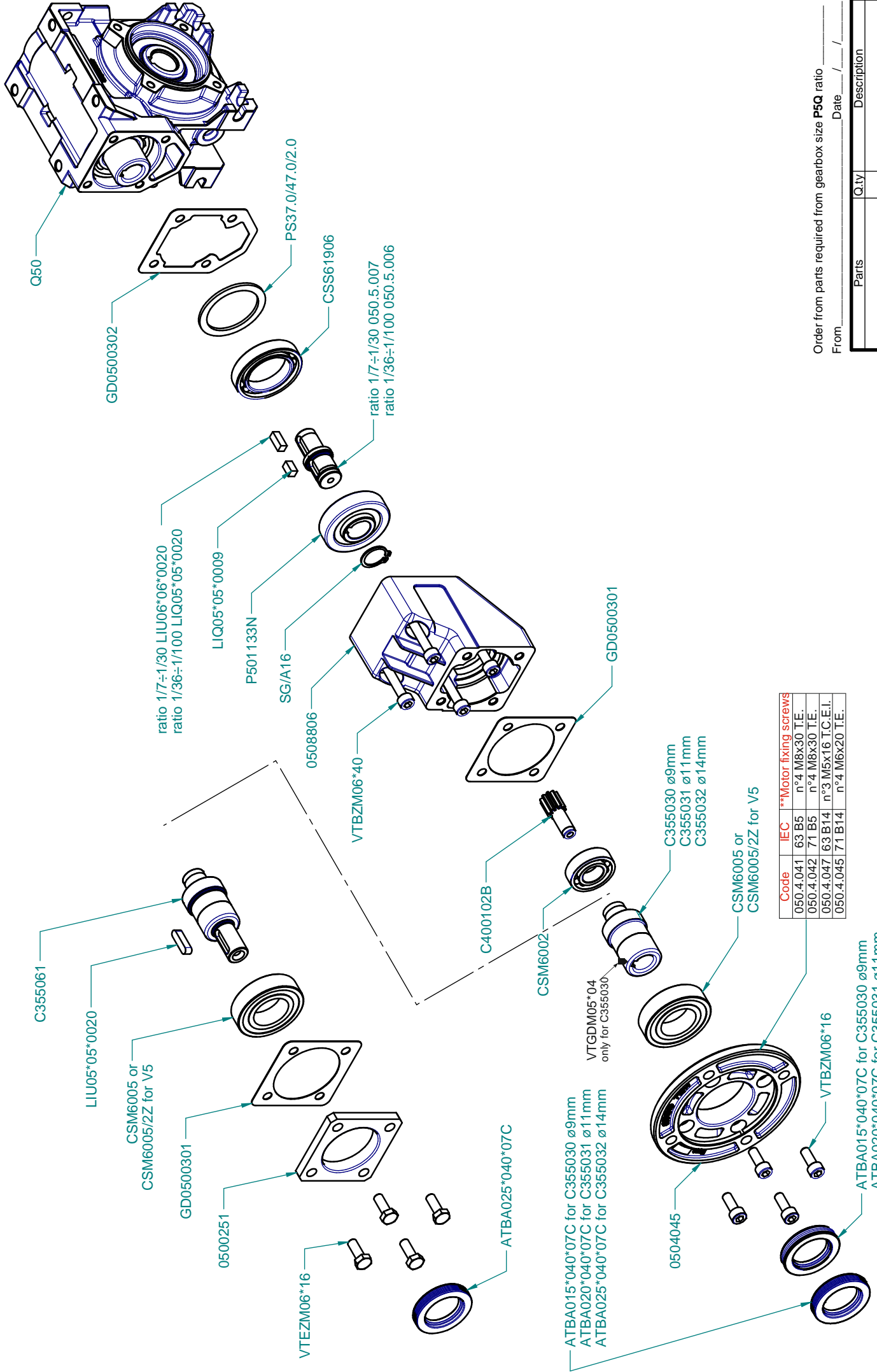

Order from parts required from gearbox size **P5Q** ratio \_\_\_\_\_  
From \_\_\_\_\_ Date \_\_\_\_/\_\_\_\_/\_\_\_\_

Parts	Q.ty	Description

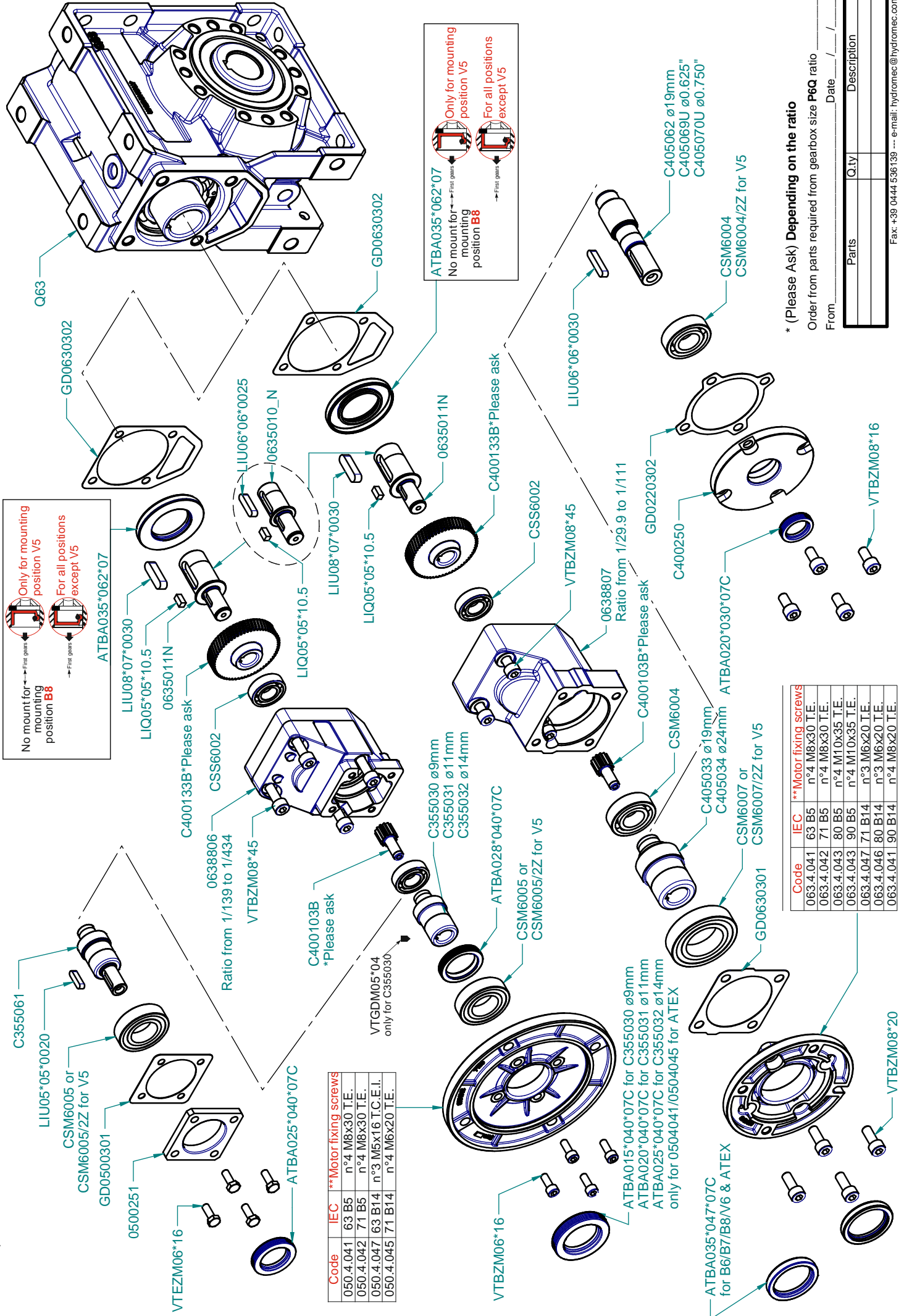

No mount for mounting position B8  
 Only for mounting position V5  
 For all positions except V5

ATBA035\*062\*07  
 No mount for mounting position B8  
 Only for mounting position V5  
 For all positions except V5

Code	IEC	**Motor fixing screws
050.4.041	63 B5	n°4 M8x30 T.E.
050.4.042	71 B5	n°4 M8x30 T.E.
050.4.047	63 B14	n°3 M5x16 T.C.E.I.
050.4.045	71 B14	n°4 M6x20 T.E.

Code	IEC	**Motor fixing screws
063.4.041	63 B5	n°4 M8x30 T.E.
063.4.042	71 B5	n°4 M8x30 T.E.
063.4.043	80 B5	n°4 M10x35 T.E.
063.4.043	90 B5	n°4 M10x35 T.E.
063.4.047	71 B14	n°3 M6x20 T.E.
063.4.046	80 B14	n°3 M6x20 T.E.
063.4.041	90 B14	n°4 M8x20 T.E.

\* (Please Ask) Depending on the ratio

Order from parts required from gearbox size P6Q ratio \_\_\_\_\_

From \_\_\_\_\_ Date \_\_\_\_\_ / \_\_\_\_\_ / \_\_\_\_\_

Parts	Q.ty	Description



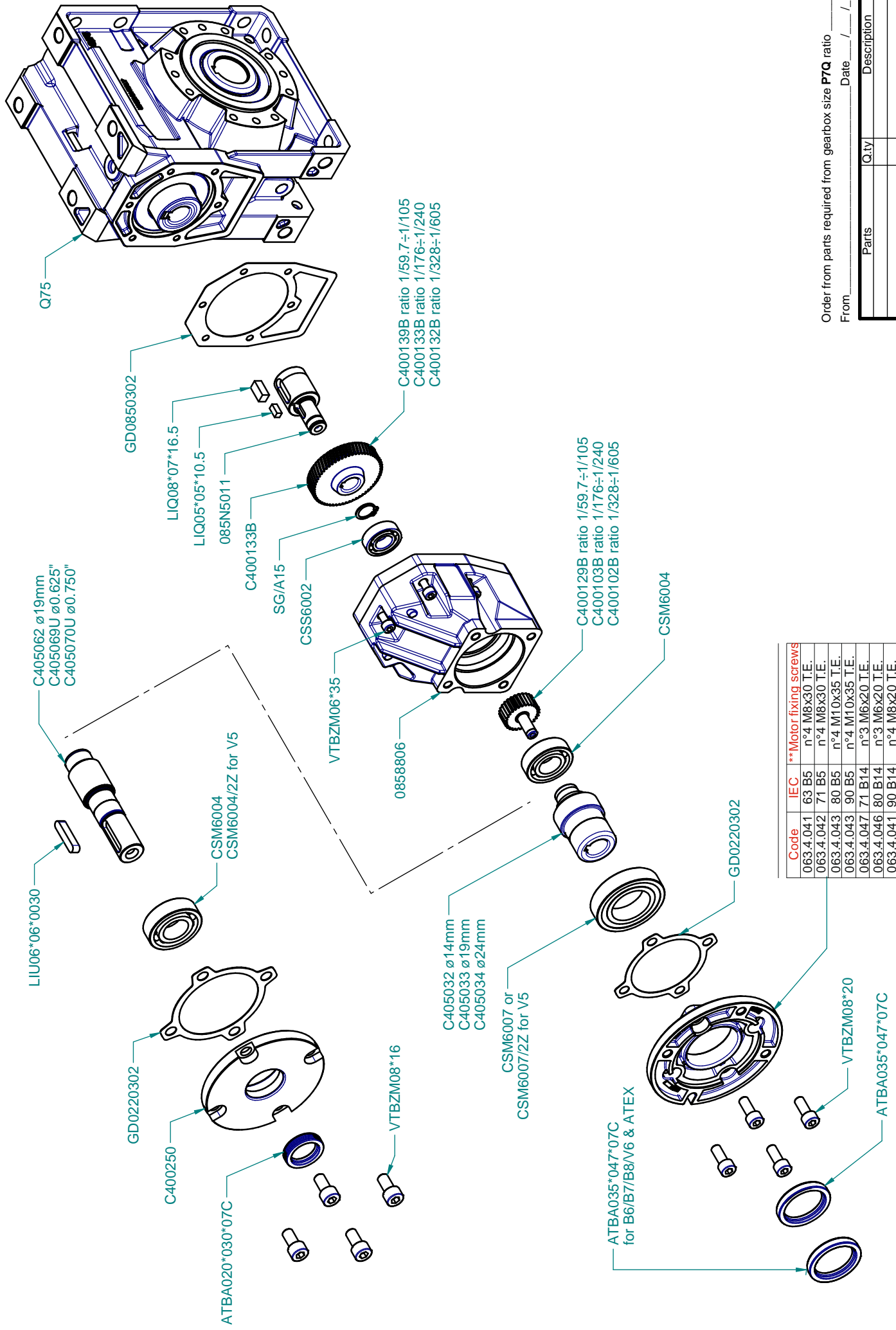

Code	IEC	** Motor fixing screws
063.4.041	63 B5	n°4 M8x30 T.E.
063.4.042	71 B5	n°4 M8x30 T.E.
063.4.043	80 B5	n°4 M10x35 T.E.
063.4.043	90 B5	n°4 M10x35 T.E.
063.4.047	71 B14	n°3 M6x20 T.E.
063.4.046	80 B14	n°3 M6x20 T.E.
063.4.041	90 B14	n°4 M8x20 T.E.

Order from parts required from gearbox size **P7Q** ratio \_\_\_\_\_

From \_\_\_\_\_ Date \_\_\_\_/\_\_\_\_/\_\_\_\_

Parts	Qty	Description

Fax: +39 0444 536139 ---- e-mail: hydromec@hydromec.com

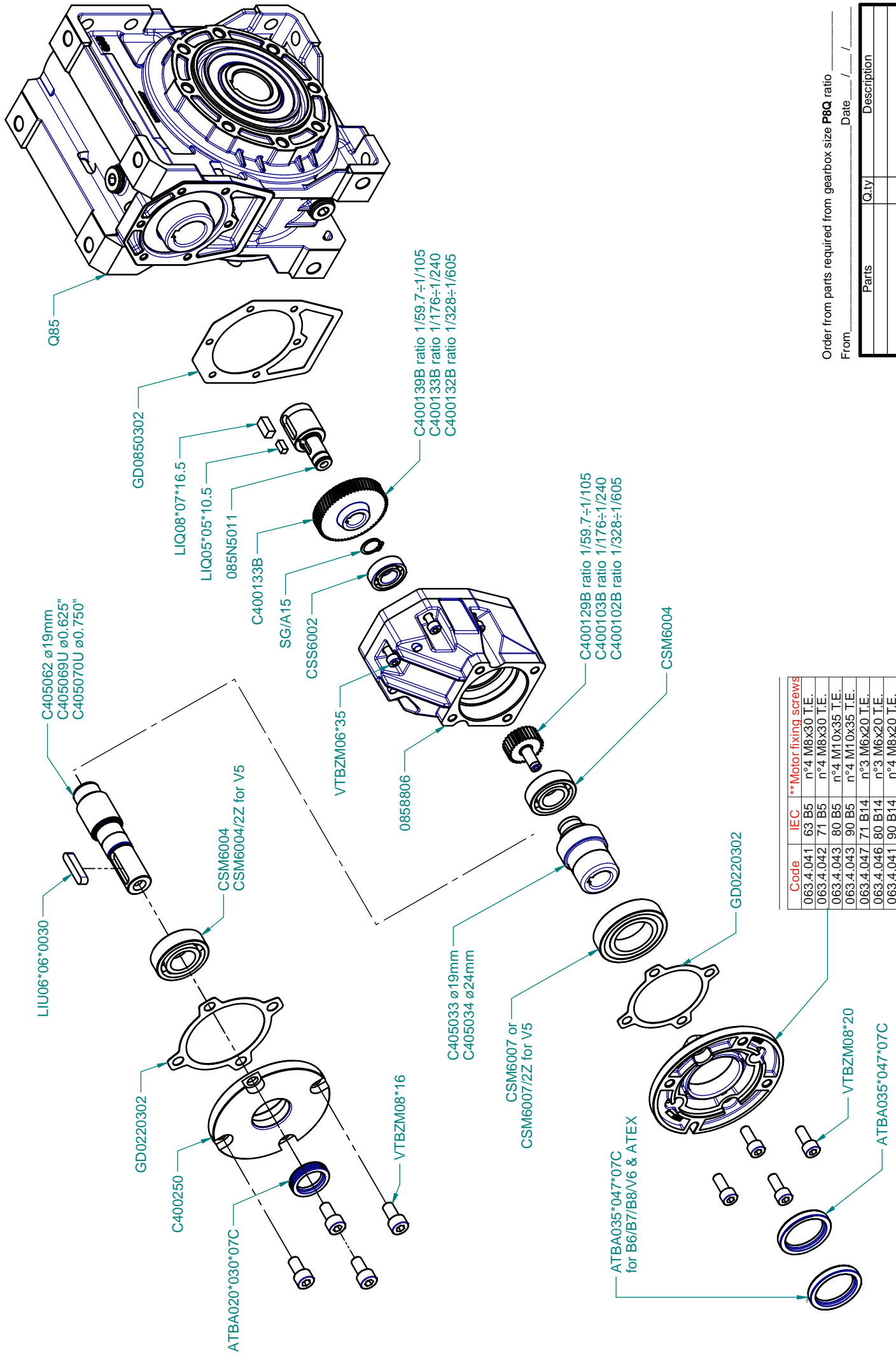

Code	IEC	** Motor fixing screws
063.4.041	63 B5	n°4 M8x30 T.E.
063.4.042	71 B5	n°4 M8x30 T.E.
063.4.043	80 B5	n°4 M10x35 T.E.
063.4.043	90 B5	n°4 M10x35 T.E.
063.4.047	71 B14	n°3 M6x20 T.E.
063.4.046	80 B14	n°3 M6x20 T.E.
063.4.041	90 B14	n°4 M8x20 T.E.

Order from parts required from gearbox size **P8Q** ratio \_\_\_\_\_

From \_\_\_\_\_ Date \_\_\_\_/\_\_\_\_/\_\_\_\_

Parts	Qty	Description

Fax: +39 0444 536139 ---- e-mail: hydromec@hydromec.com



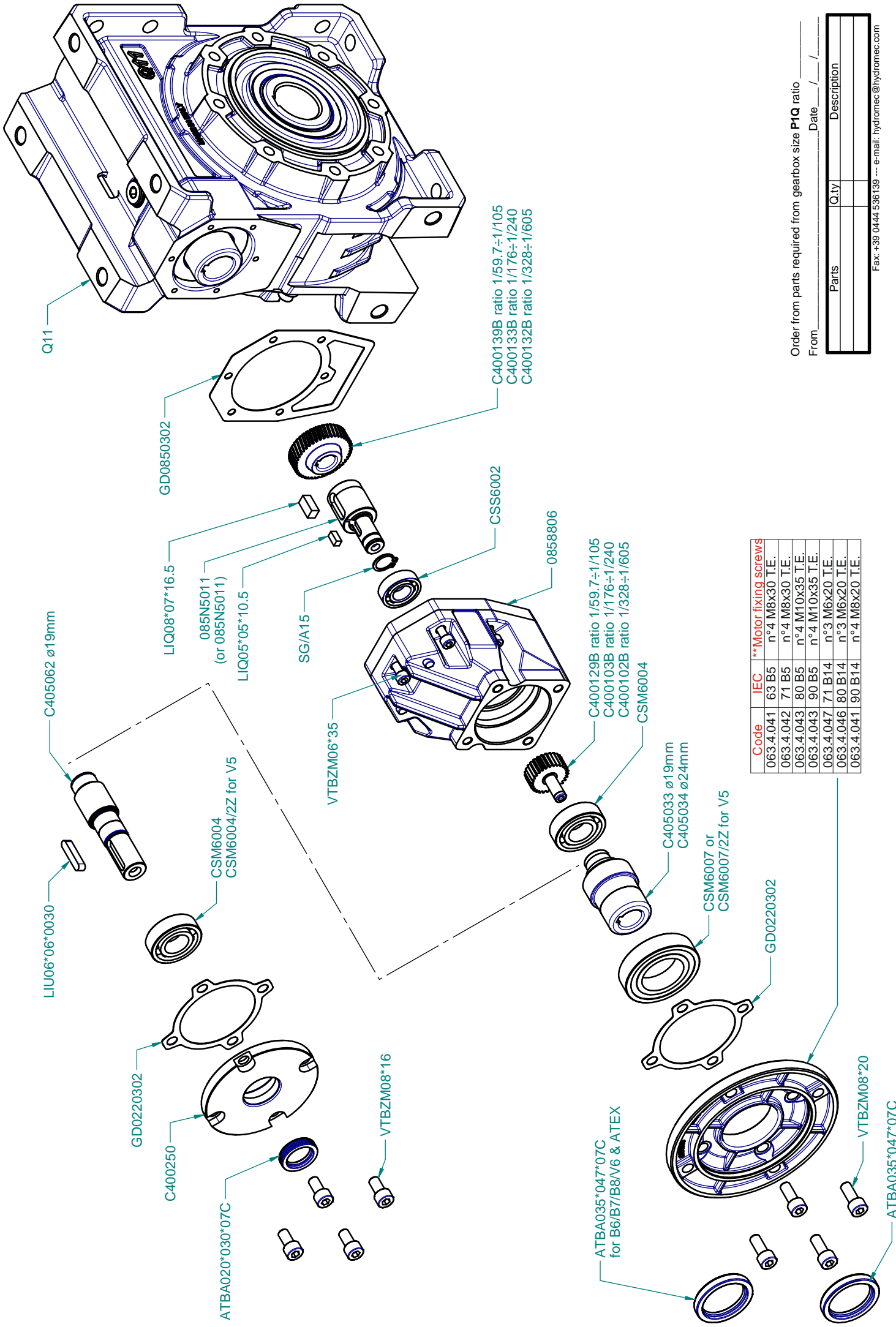

Code	IEC	**Motor fixing screws
063.4.041	63 B5	n°4 M8x30 T.E.
063.4.042	71 B5	n°4 M8x30 T.E.
063.4.043	80 B5	n°4 M10x35 T.E.
063.4.043	90 B5	n°4 M10x35 T.E.
063.4.047	71 B14	n°3 M6x20 T.E.
063.4.046	80 B14	n°3 M6x20 T.E.
063.4.041	90 B14	n°4 M8x20 T.E.

Order from parts required from gearbox size **P1Q** ratio \_\_\_\_\_  
 From \_\_\_\_\_ Date \_\_\_\_/\_\_\_\_/\_\_\_\_  

Parts	Q.ty	Description

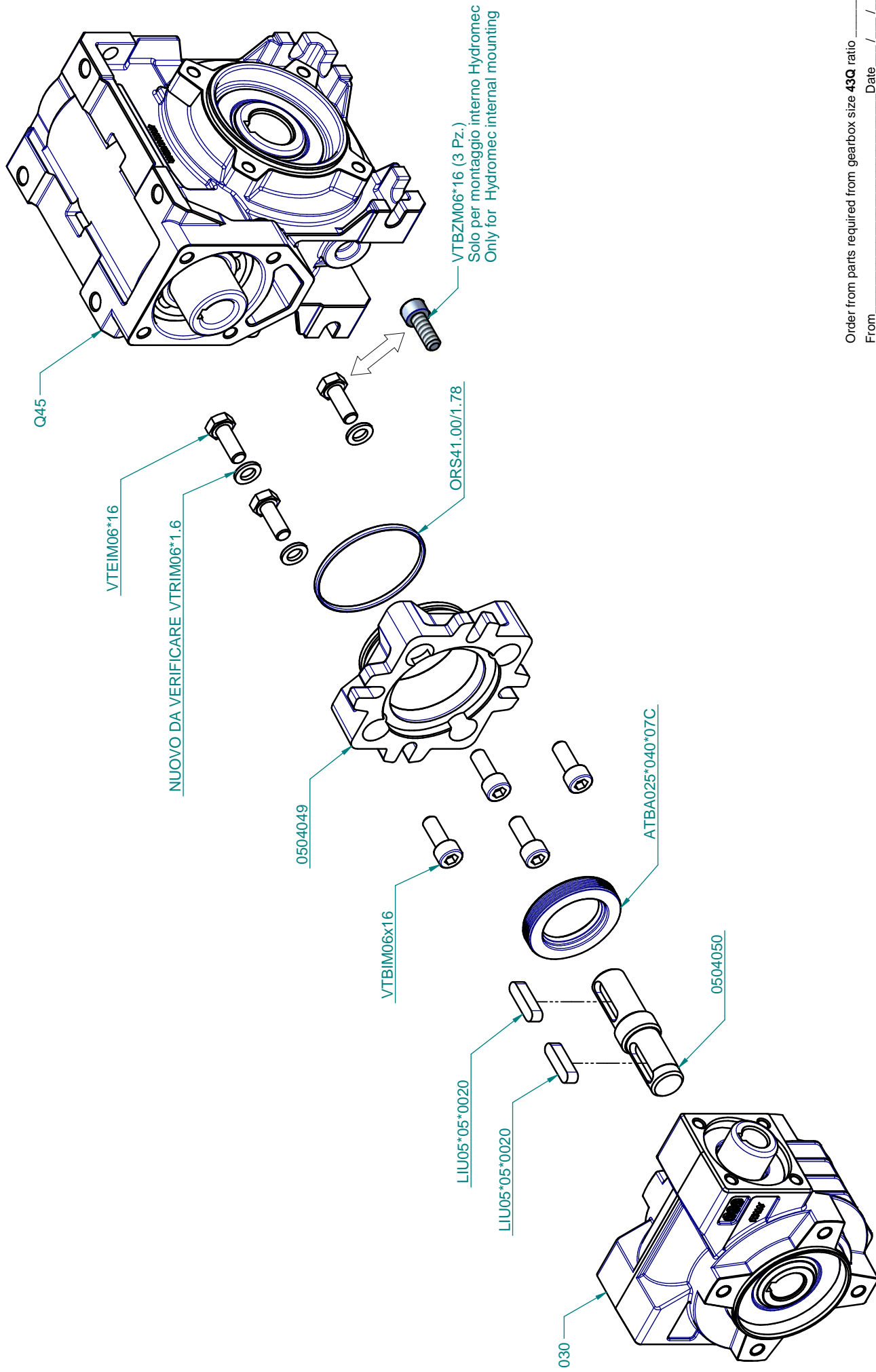

Order from parts required from gearbox size **43Q** ratio \_\_\_\_\_  
From \_\_\_\_\_ Date \_\_\_\_/\_\_\_\_/\_\_\_\_

Parts	Q.ty	Description

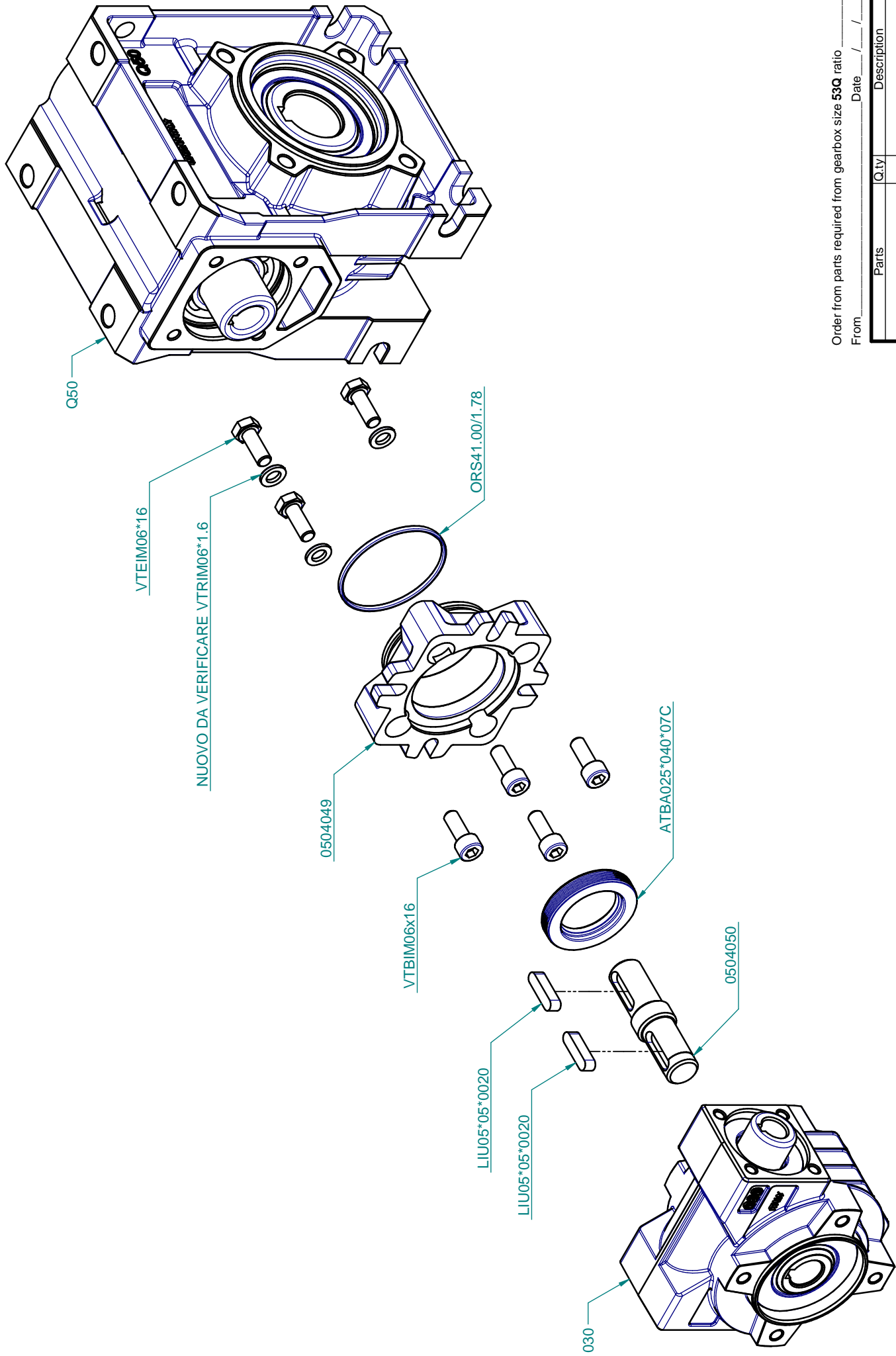

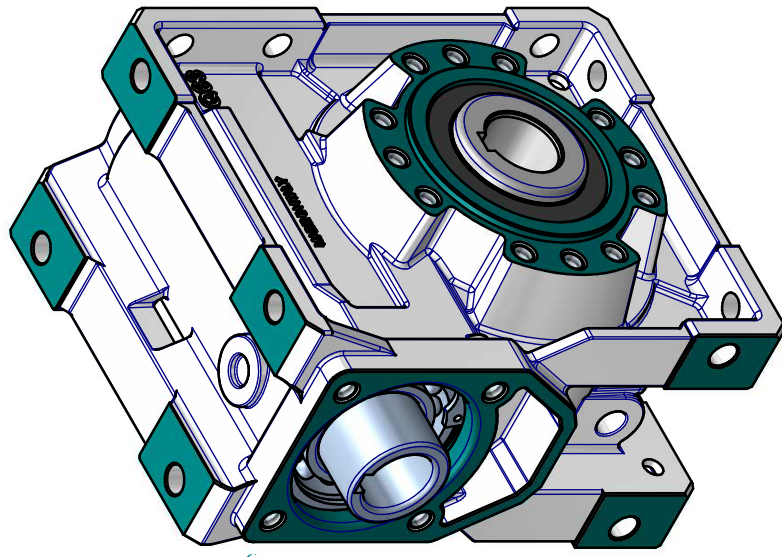

Q63

GD0220302

ATBA035\*052\*07

0634049

LIU08\*07\*0030

LIU05\*05\*0020

0634051  
Ø24mm

VTEIM06\*16 (4Pz.)

NUOVO DA VERIFICARE VTRIM06\*1.6 (4Pz.)

VTEIM08\*20 (4Pz.)

LIU08\*07\*0030

LIU05\*05\*0020

0634050  
Ø19mm

030

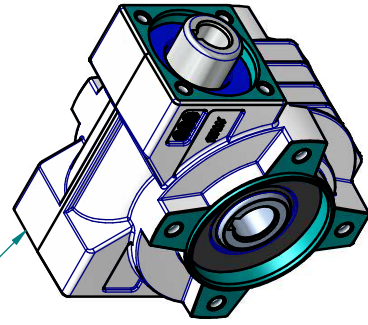

Order from parts required from gearbox size **63Q** ratio \_\_\_\_\_

From \_\_\_\_\_ Date \_\_\_\_/\_\_\_\_/\_\_\_\_

Parts	Q.ty	Description

Fax: +39 0444 536139 ---- e-mail: hydromec@hydromec.com

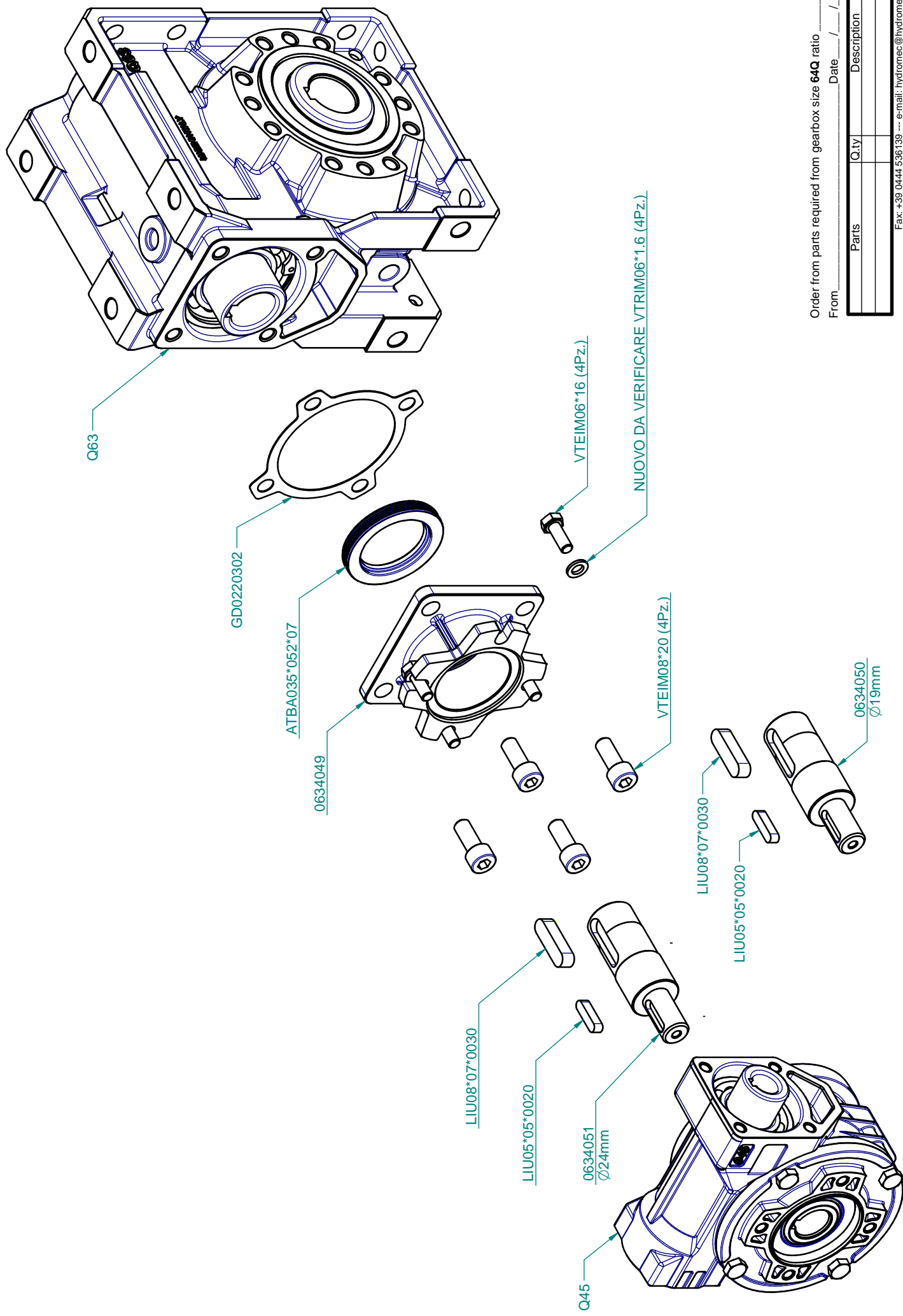

Order from parts required from gearbox size **64Q** ratio \_\_\_\_\_  
From \_\_\_\_\_ Date \_\_\_\_/\_\_\_\_/\_\_\_\_

Parts	Q.ty	Description



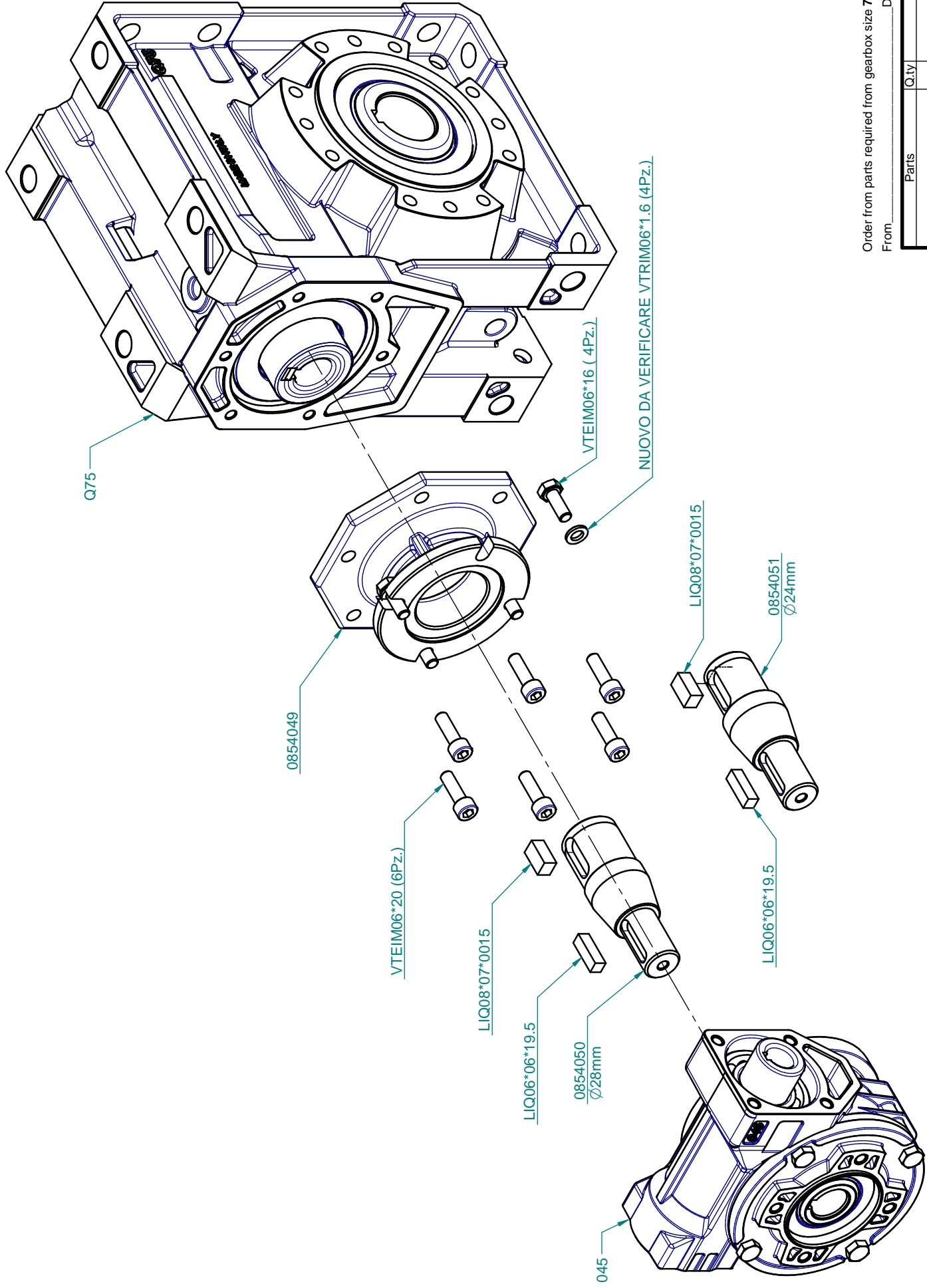

Order from parts required from gearbox size **74Q** ratio \_\_\_\_\_  
From \_\_\_\_\_ Date \_\_\_\_/\_\_\_\_/\_\_\_\_

Parts	Q.ty	Description

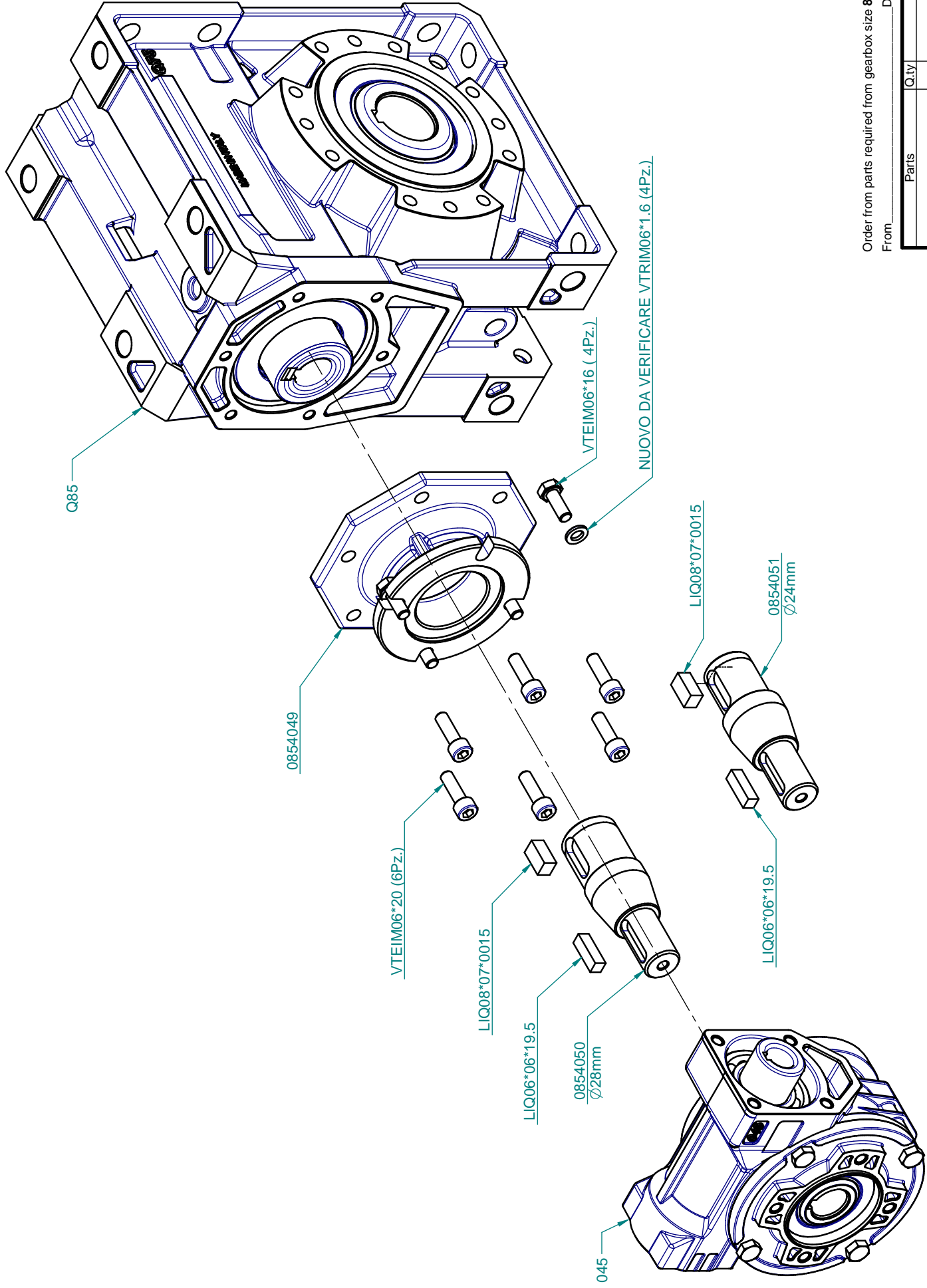

Order from parts required from gearbox size **84Q** ratio \_\_\_\_\_  
From \_\_\_\_\_ Date \_\_\_\_/\_\_\_\_/\_\_\_\_

Parts	Q.ty	Description

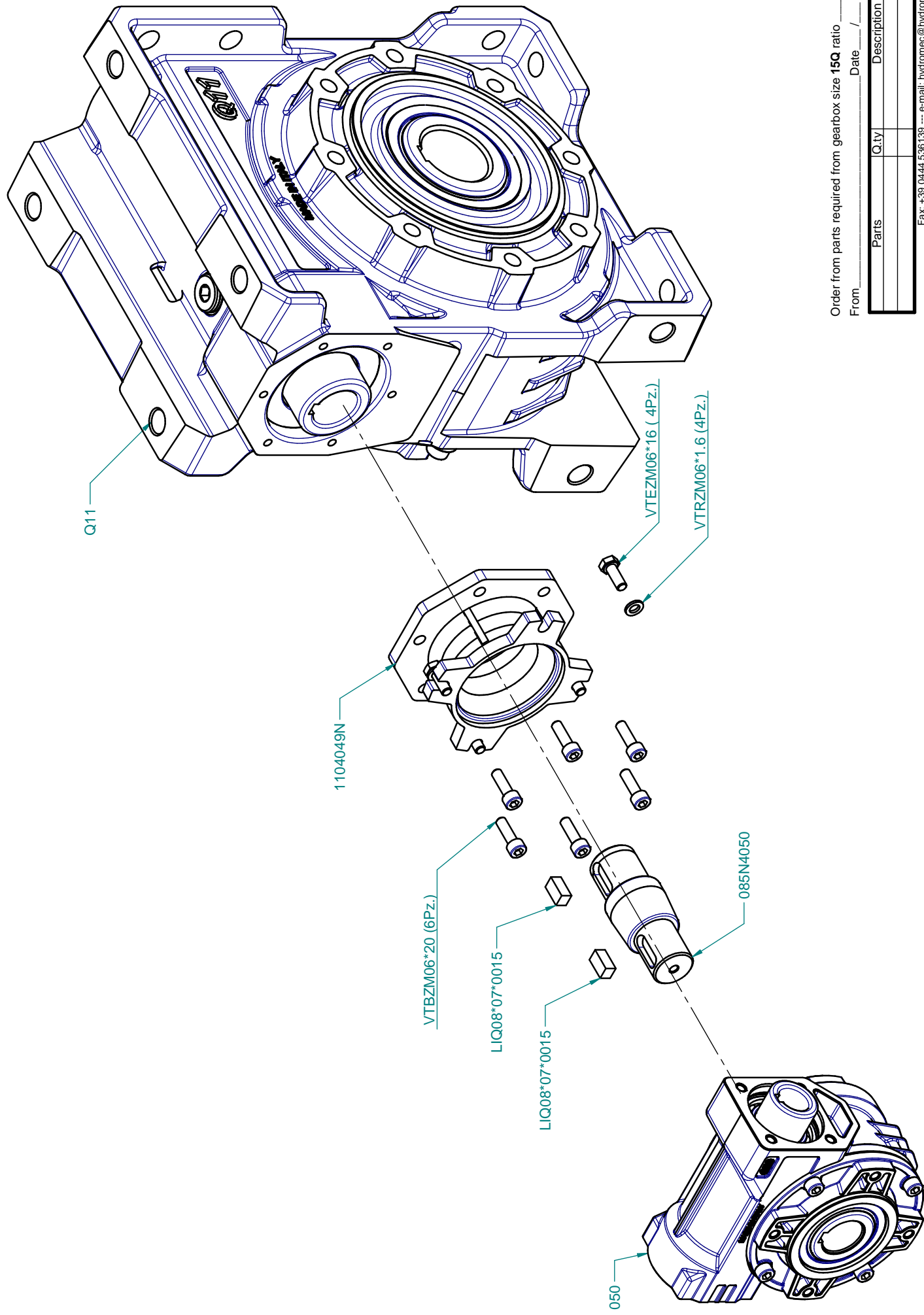

Order from parts required from gearbox size **15Q** ratio \_\_\_\_\_

From \_\_\_\_\_ Date \_\_\_\_/\_\_\_\_/\_\_\_\_

Parts	Q.ty	Description

Fax: +39 0444 536139 ---- e-mail: [hydromec@hydromec.com](mailto:hydromec@hydromec.com)









# HYDRO-MEC

[www.hydromec.com](http://www.hydromec.com)

Distributed from

